

Operations Manual

Thermal Jet Ink Jet System

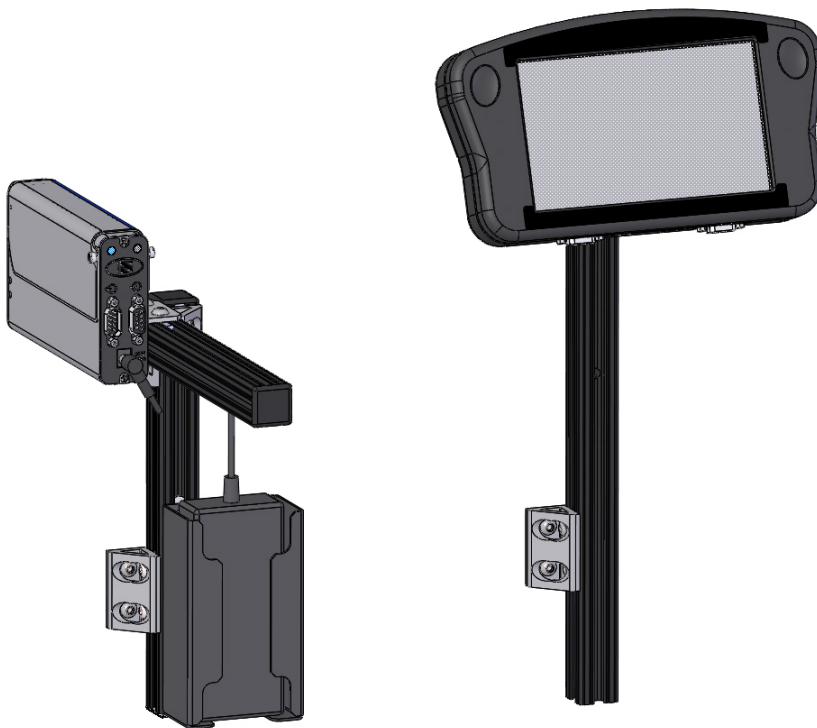

5780-649FX
Revision B

Thermal Jet Ink Jet System Operations Manual

5780-649FX
Revision B

Ink Cartridge: The SoloSeries has been engineered and designed to work with Foxjet ink cartridges. The SoloSeries' **Smart Level Ink Detection System**, which provides ink level monitoring to ensure complete ink usage and product safety, will not be functional if used with non-Foxjet ink cartridges.

The information contained in this manual is correct and accurate at the time of its publication. Foxjet reserves the right to change or alter any information or technical specifications at any time and without notice.

©2016 Illinois Tool Works Inc.

All rights reserved

Printed in the United States of America

SoloSeries *Thermal Jet*

Warranty:

The SoloSeries Thermal Jet system, including all components unless otherwise specified, carries a limited warranty.

The inks and conditioners used with the SoloSeries Thermal Jet system carry a limited warranty.

For all warranty terms and conditions, contact Foxjet an ITW Company for a complete copy of the Limited Warranty Statement.

Thermal Jet

Section 1: Safety and Ink Cartridge Usage	1
Section 2: Quick Start	2
Step 1: Assemble Bracketry	3
Step 2: Assemble Bracketry to Conveyor	3
Step 3: Assemble Print Head and Power Supply to Bracketry	4
Step 4: Adjust Print Head to Substrate	5
Step 5: Insert Pen Cartridge into Print Head	6
Step 6: Cabling, Power, and Serial Port Setup	7
Step 7: Configure the Print Head	10
Step 8: Create a Message	11
Step 9: Print a Message	12
Section 3: User Interface	13
Home Screen:	14
Message Editor	17
Time, Date, and Count Codes	18
User Defined Time Codes	19
User Defined Date Codes	20
Product Counts, Variable Fields, Logos	21
Barcodes, Lines, Product setup, & Menu	22
Message Info Box	23
Zoom	23
Delete Button	23
The Apps Screen	24
Section 4: Maintenance & Shutdowns	26
Pen Cartridge Maintenance	26
Section 5: Troubleshooting	28
Appendix A: Specifications	30
Handheld Serial Controller	33
System Interconnect Diagram	34
Appendix B: Theory of Operation	35
Thermal Jet Print Heads	35
Handheld Controller	36
Appendix C: File Backup and Restore	38
From a PC	38
File Backup	39
Restoring Backed-Up Files	40
From a Controller	41

Thermal Jet

Appendix D: Configuring a PC to Communicate with the Handheld	42
Windows XP®	42
Window 7®	44
Appendix E: Font Samples	45
Appendix F: Creating Logo Files	46
Appendix G: Controller and Print Head File Management	47
File Manager	47
Transferring Logo and Font Files	48
Removing a File	49
Appendix H: Communicating Directly to the Print Head	50
Appendix I: Aligning the 1" (25.4 mm) Print Head	51
Appendix J: Bulk Ink Supply	52
Appendix K: Part Numbers - Consumables and Service Parts	58
Service Parts	58
Optional Equipment	61

Section 1: Safety and Ink Cartridge Usage

Following is a list of safety symbols and their meanings, which are found throughout this manual. Pay attention to these symbols where they appear in the manual.



Wear safety goggles when performing the procedure described!



Caution or Warning! Denotes possible personal injury and/or damage to the equipment.



Caution or Warning! Denotes possible personal injury and/or equipment damage due to electrical hazard.



NOTE: (Will be followed by a brief comment or explanation.)



ESD protection should be worn when servicing internal printed circuit boards.
After service to the equipment is completed, replace all protective devices such as grounding cables and covers before operating the equipment.



It is extremely important to:

- Clean up all spills with the appropriate solvents immediately and dispose of all waste according to local and state regulations.
- Wear safety glasses and protective clothing, including gloves, when handling all inks and conditioners.
- Store inks and solvents under the recommended conditions found on the SDS (Safety Data Sheet).

Section 2: Quick Start

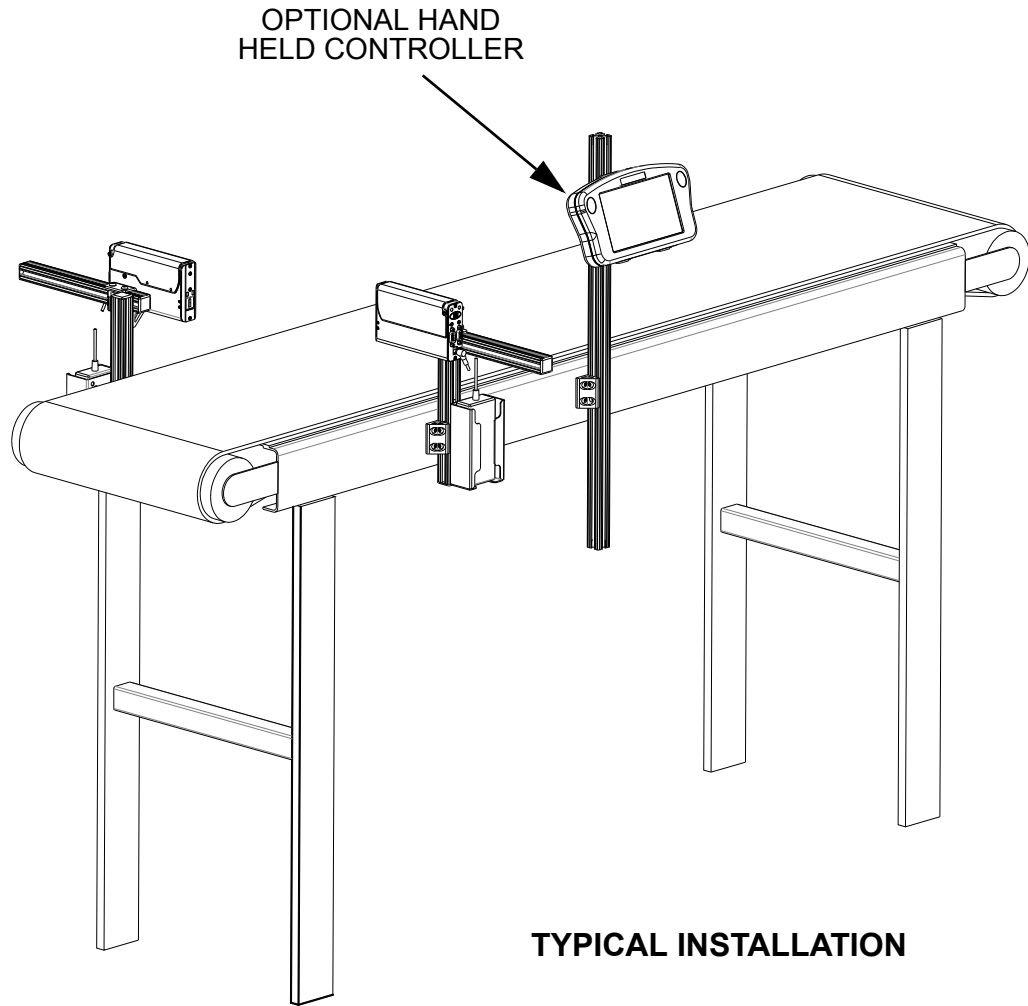

Contents:

- Print Head
- Bracketry Kit
- Power Supply, 15 V
- Power Supply Bracket
- Power Cord
- Software

Step 1: Assemble Bracketry

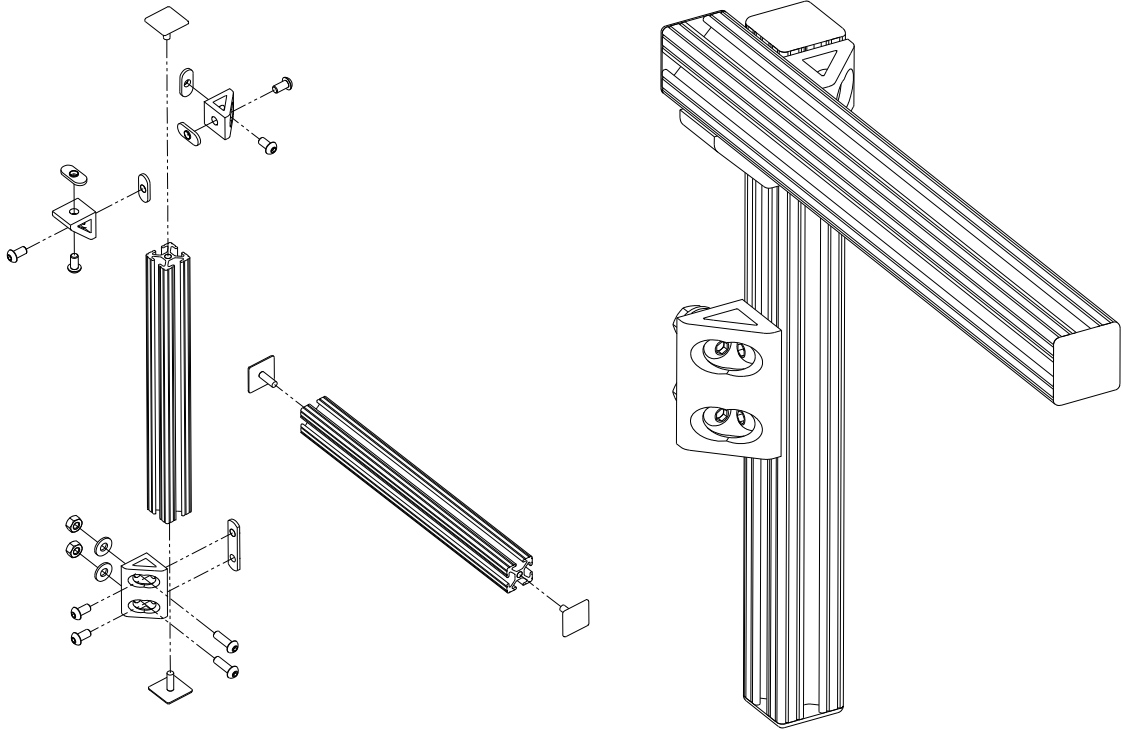

Step 2: Assemble Bracketry to Conveyor

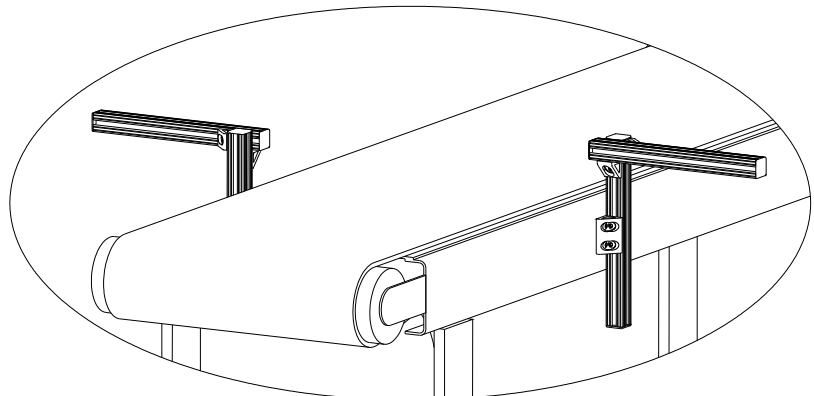
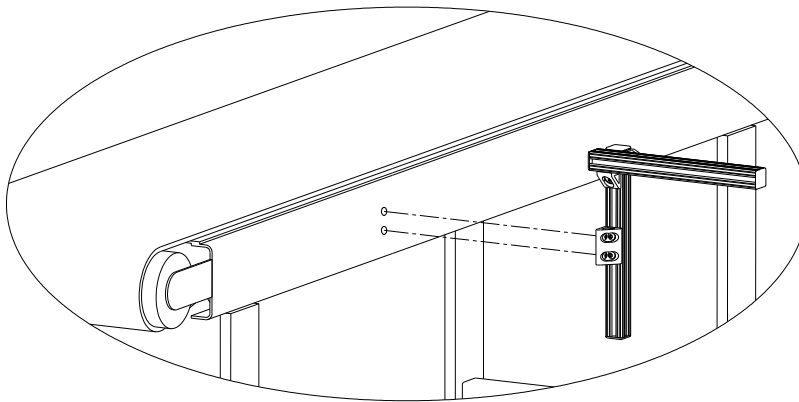

Step 3: Assemble Print Head and Power Supply to Bracketry

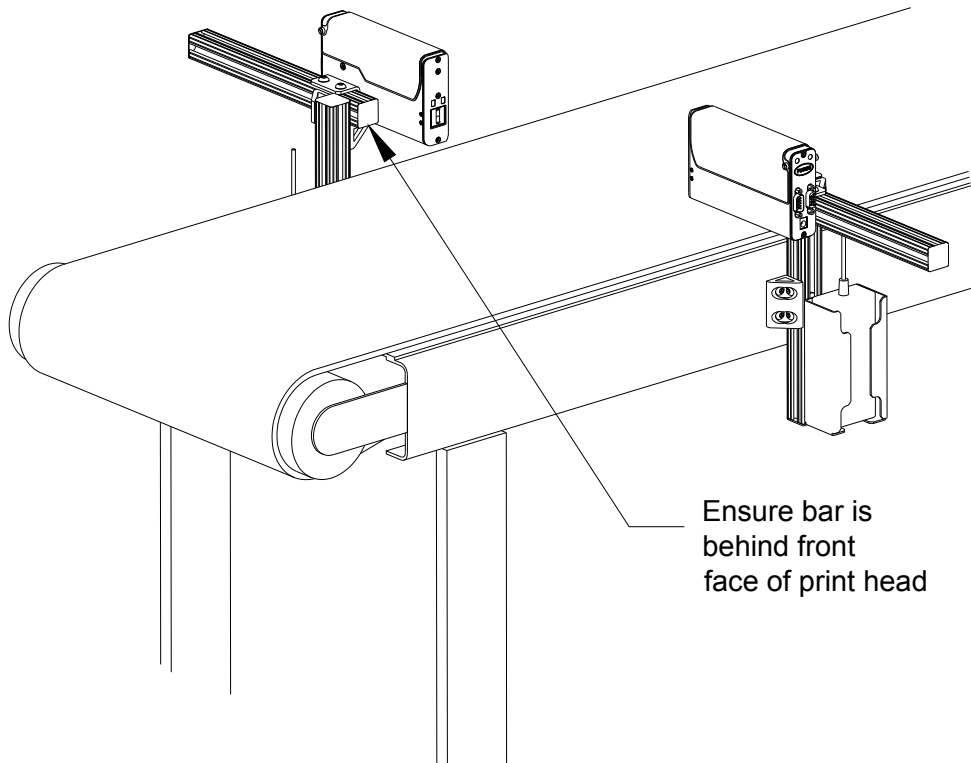
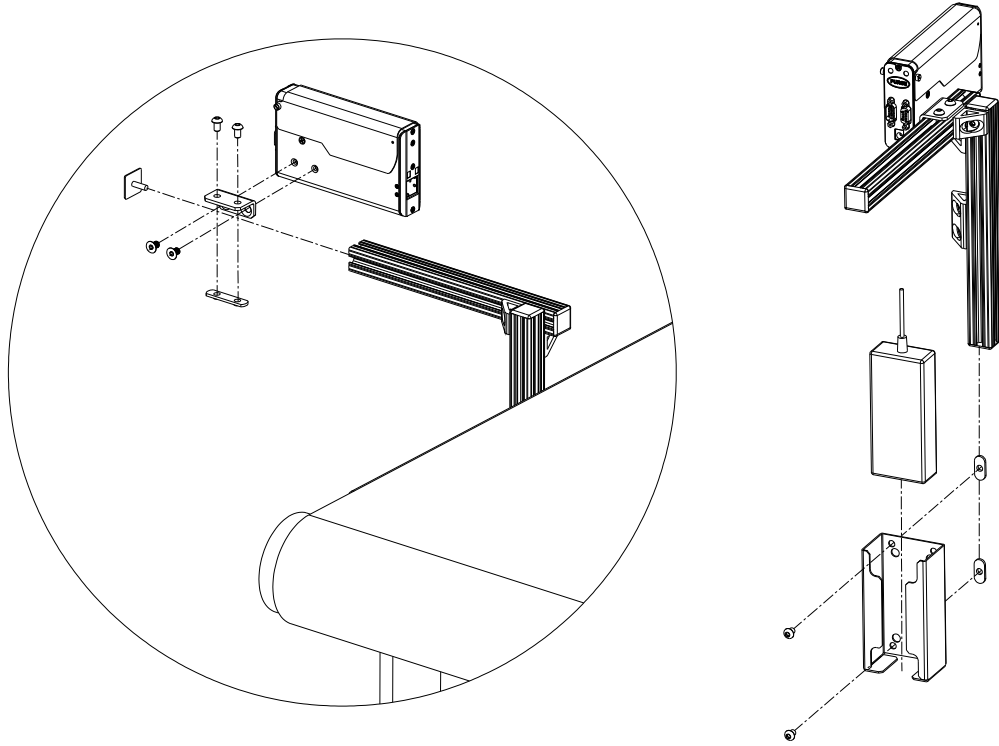

Step 4: Adjust Print Head to Substrate

Adjust print head vertically to meet requirement.

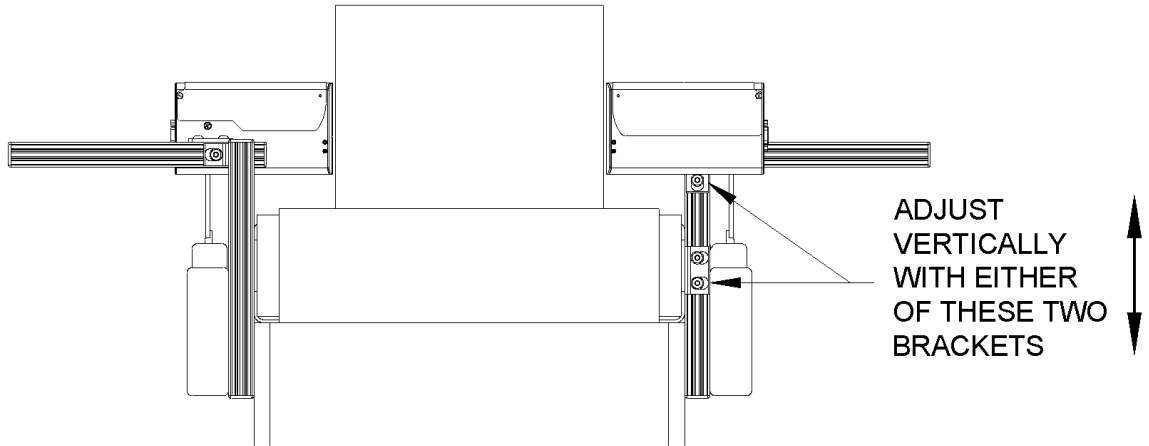

Adjust print head horizontally to set print gap.

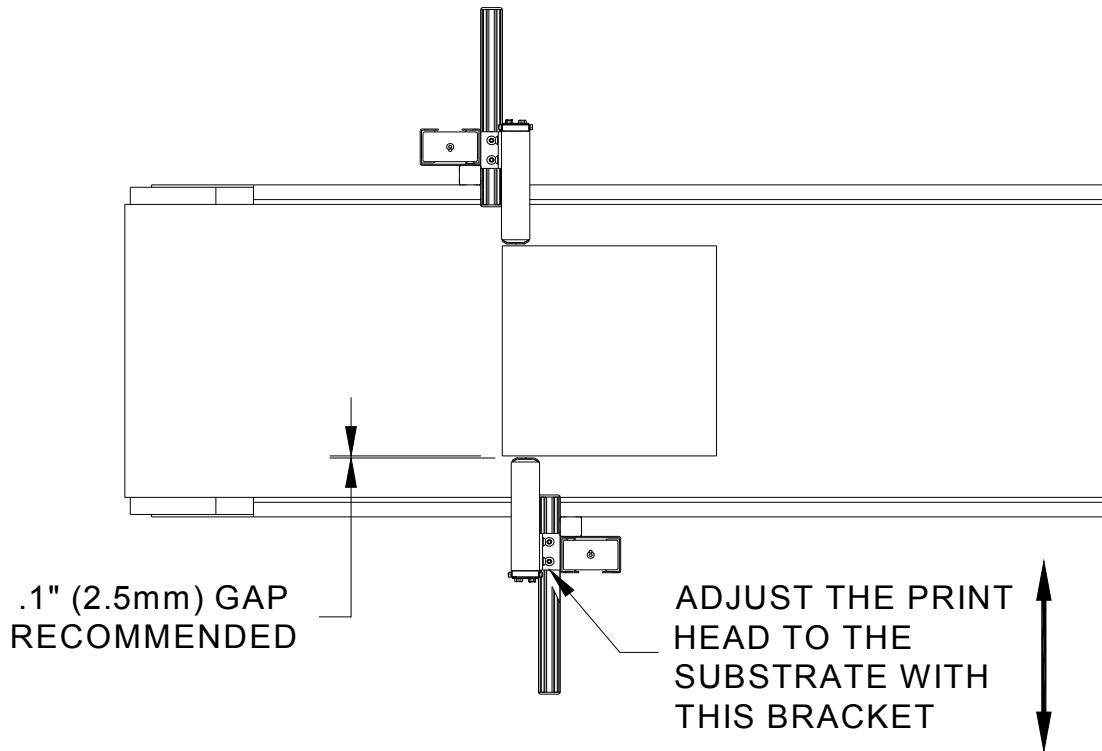

Step 5: Insert Pen Cartridge into Print Head

Rotate Cover Open

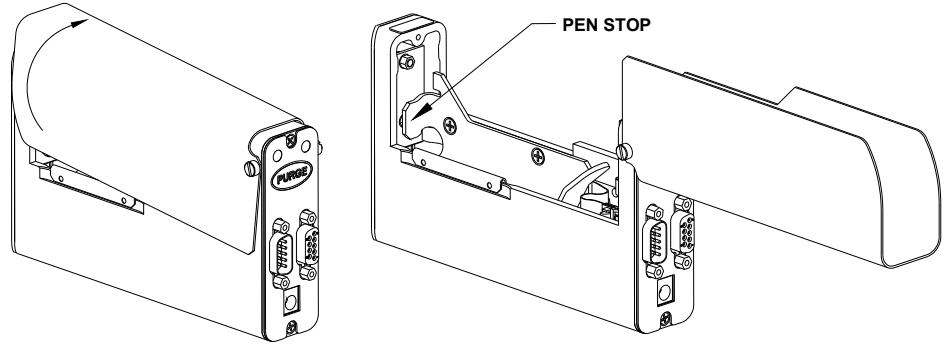

Insert Pen Cartridge at an angle up to Pen Stop

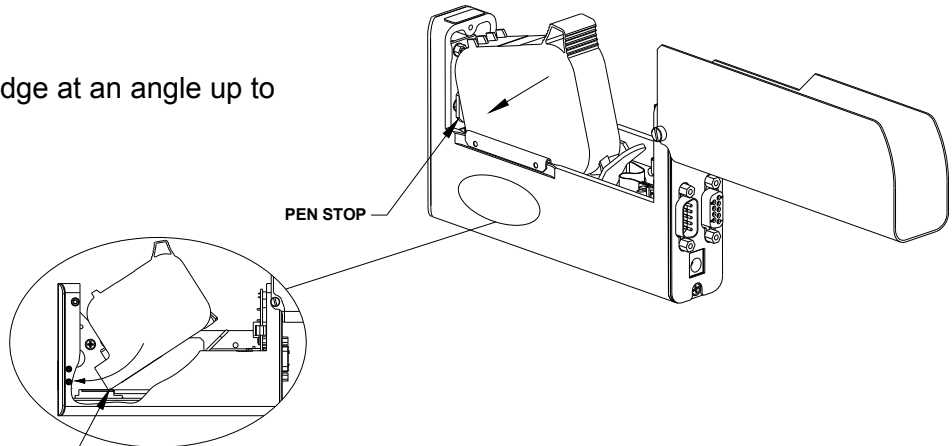

When inserting cartridge, aim nose at an angle towards black pogo pin component. Slide pen cartridge up to Pen Stop.

Rotate Pen Cartridge down until it snaps in place.



NOTE: The pen is released by pressing down on the Finger Release Tab and pulling up on the rear of the cartridge.

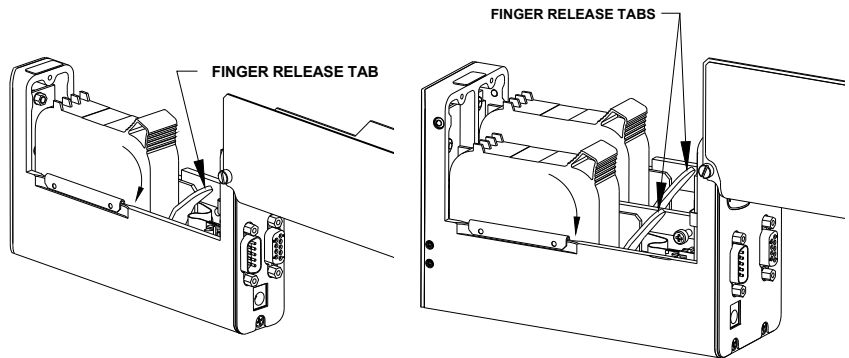

Close Cover

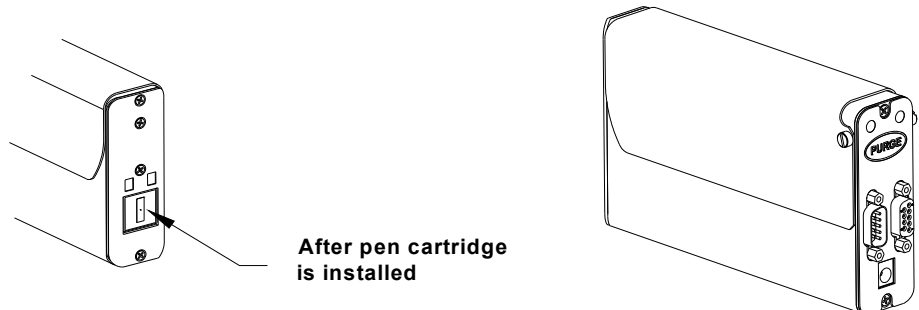

Step 6: Cabling, Power, and Serial Port Setup

Cabling



CAUTION: Power should be disconnected from the print head prior to connecting or disconnecting any external device, including: PC, controller, or print head daisy chain cables. Electrical arcing may occur if external cabling is connected or disconnected while power is supplied to the unit.

Print heads are controlled via a COM port from a PC or a Hand Held Controller. One com port can control up to eight 1/2" print heads, four 1" print heads, or any combination of the two totaling eight print cartridges. Using the supplied serial cables, connect the print heads daisy chain style by connecting the output port of one print head to the input port of the next. Then connect the COM port of the PC or Hand Held Controller to the daisy chain. A PC connects to the input port of the first head in the daisy chain, while a Hand Held Controller connects to the output port of the last.

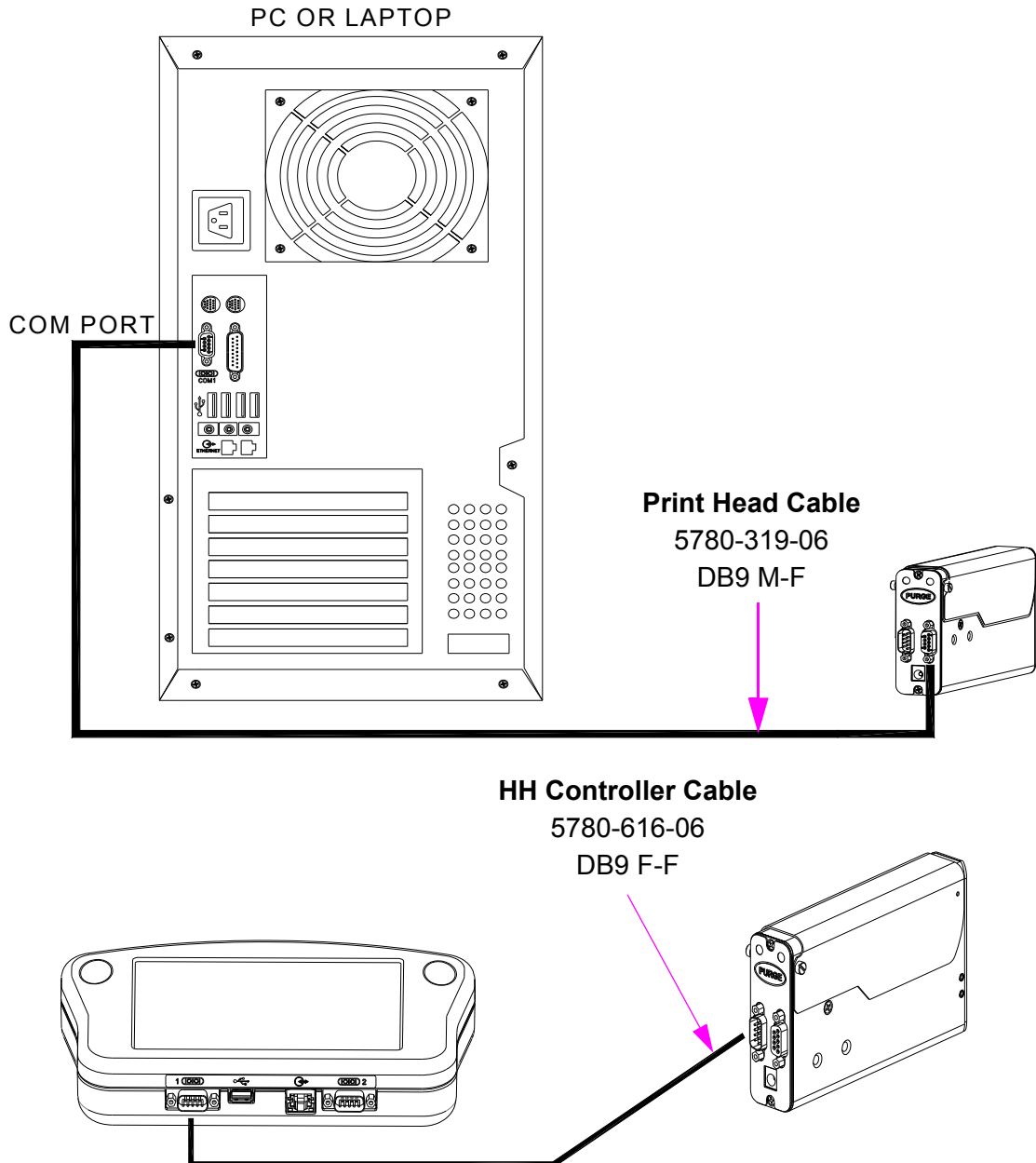

Thermal Jet

Power



CAUTION: Power should be disconnected from the print head prior to connecting or disconnecting any external device, including: PC, controller, or print head daisy chain cables. Electrical arcing may occur if external cabling is connected or disconnected while power is supplied to the unit.

Install the power plug from the previously mounted power supply into the power jack on the rear of each print head.

Press and hold the "PURGE" button on the rear of the print head while slowly moving a piece of paper, cardboard, or comparable material in front of the print head. Print several purge images and validate that all channels are printing. If not, refer to "Section 4: Maintenance & Shutdowns" on page 26.

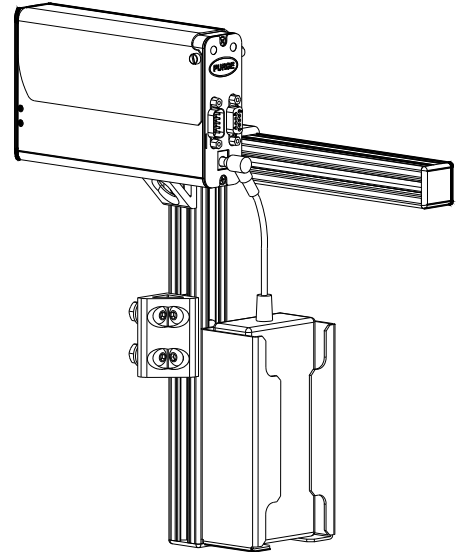

NOTE: Do not rub the print cartridge face with the print sample material as this will scratch the orifice array and affect print quality.

The power supply for the controller or the computer may now be installed.



Serial Port Setup

NOTE: Depending on the InkJet Demo software or controller configuration, this step may already be complete.

If a computer will be used, install the InkJet Demo software included with the print head. Follow the installation prompts, and at this prompt, select "Interface 1 Serial Print Head".

Launch the program after it has been installed.

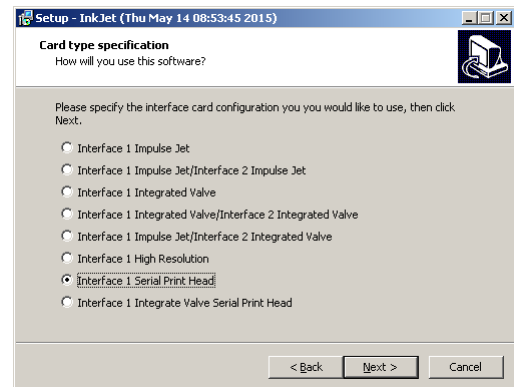

On the Home Screen press the Menu Button, then the Apps Button.

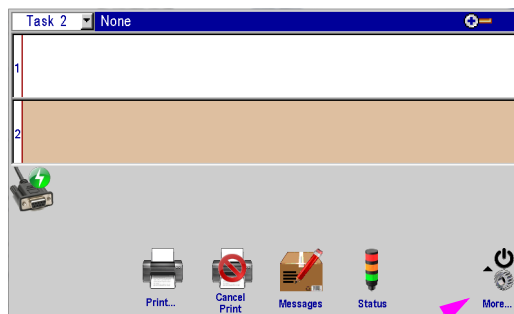

Menu Button

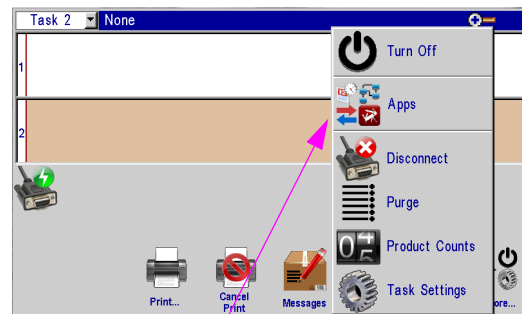

Apps Button

Thermal Jet

On the **Apps** screen, Press the **Ports** button.

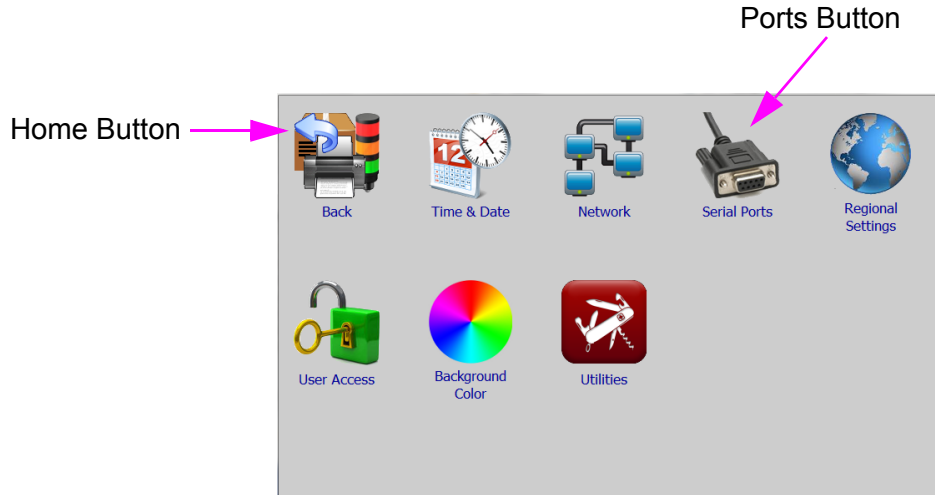

On the Ports Setting Screen press the **COM1** Function Button, select **Serial Print Head-HP**, and press OK. Press OK again to exit the Port Settings Screen.

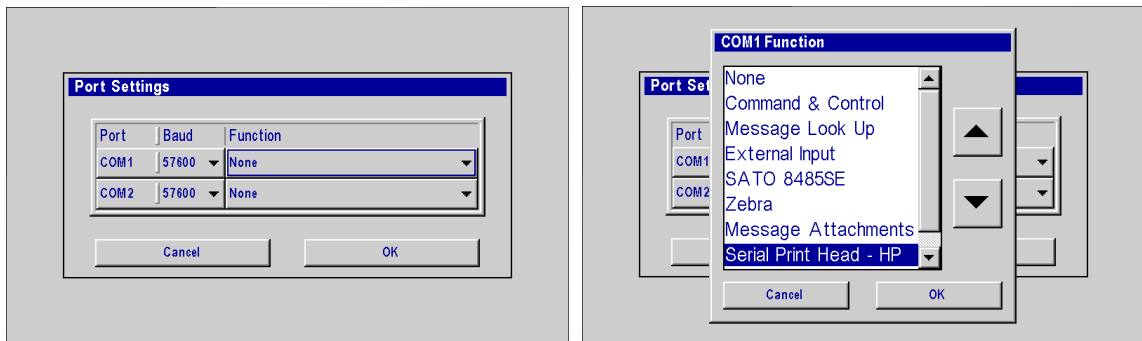

If using a PC, pressing OK after selecting Serial Print Head-HP opens the Serial Port Setup dialog box. Select the desired COM port (only those ports available are listed) and press OK. Press OK again to exit the Port Settings Screen.

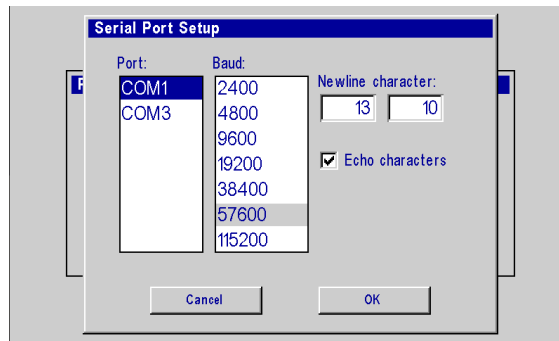

Press the Home Button to return to the Home Screen.

Thermal Jet

Step 7: Configure the Print Head

On the home screen, press the **More** button, and then press **Task Settings**. On the **Print Heads** page, press the **Redo Setup** button. Select the desired direction.

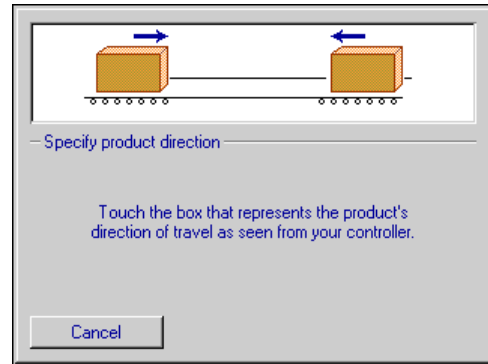
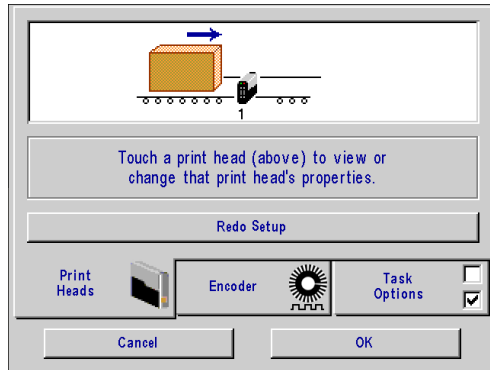

Set the number of print heads, identify their positions relative to the controller, and select the appropriate print head type by touching each one and then the drop down box. If using an external photocell, set the offset.

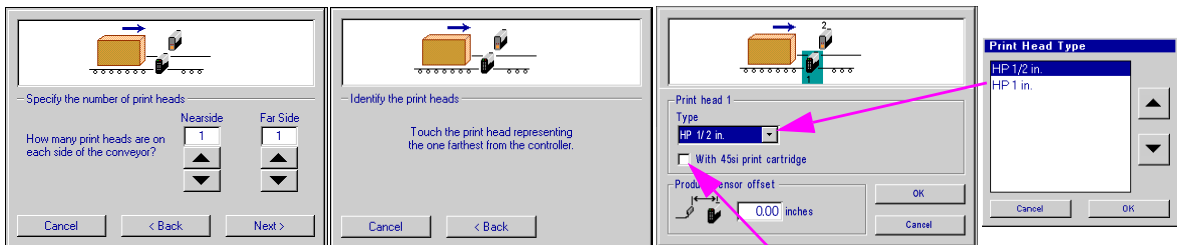

Check this box if using 5780-261FX ink cartridge.

Print head setup complete. Next, select the **Encoder** tab and choose the desired encoder type.

External Encoder:

Line speed measured by an externally mounted encoder connected to the last print head in the daisy chain

Auto Speed Detect:

Line speed automatically detected via print head photo cells.

Fixed Speed:

User enters the desired line speed

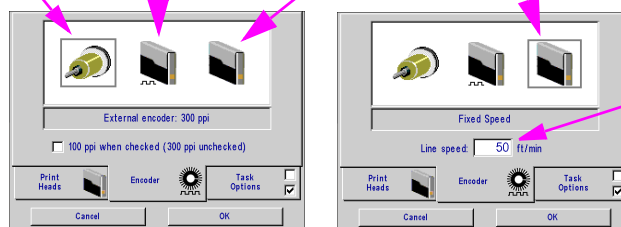

Touch this box, then enter the desired speed

Thermal Jet

Step 8: Create a Message

From the **Home Screen**, select the **Messages** button and then the **New** button to enter the message editor.

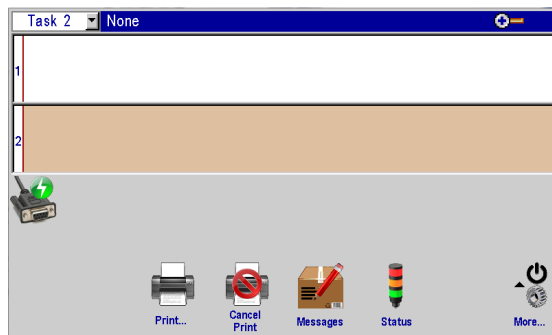

Messages Button

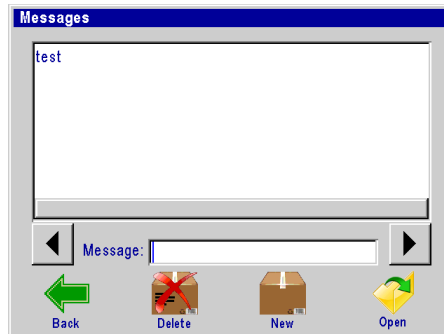

New Message Button

Create and save the message, and then exit the message editor.

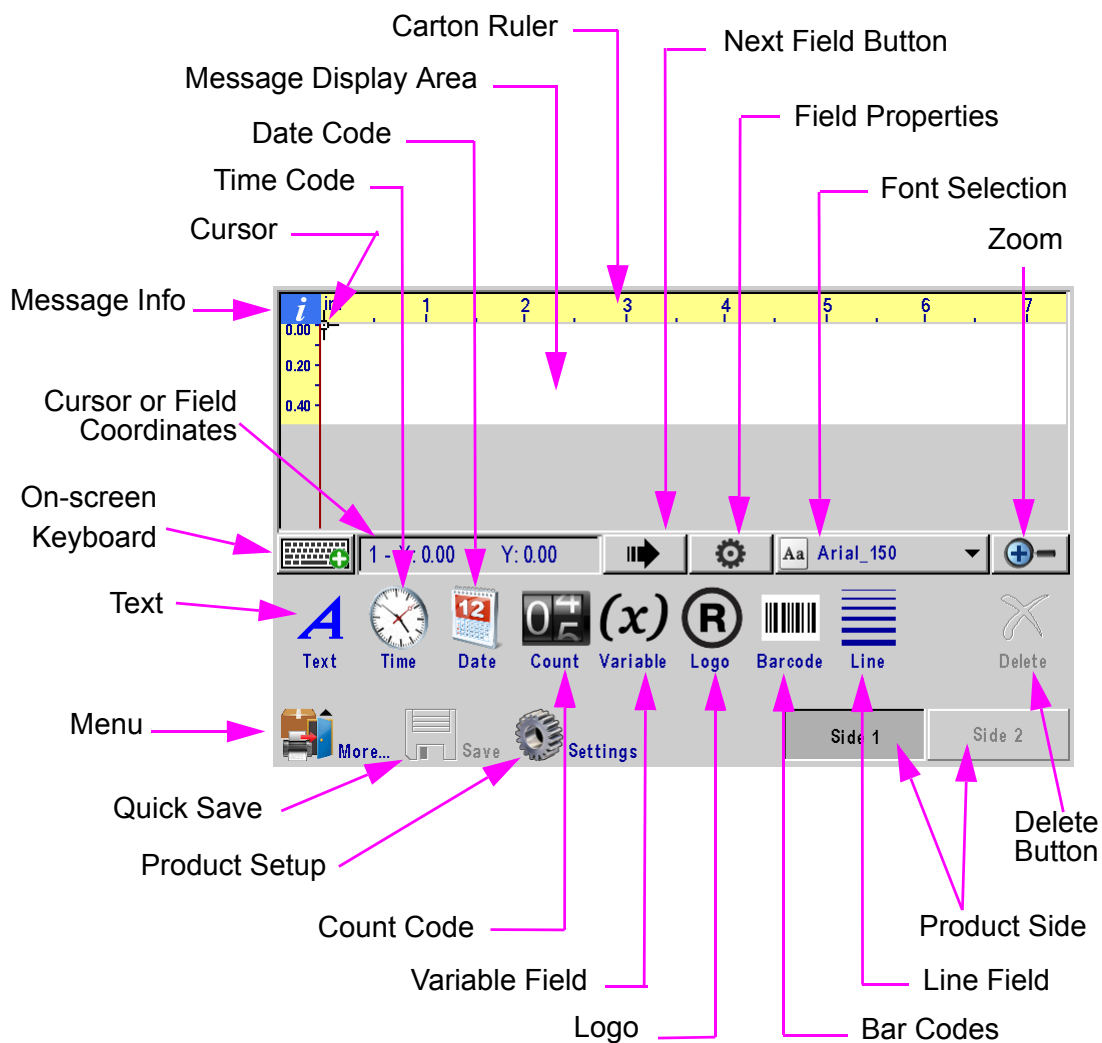

Thermal Jet

Step 9: Print a Message

From the **Home Screen**, press the **Print** button.

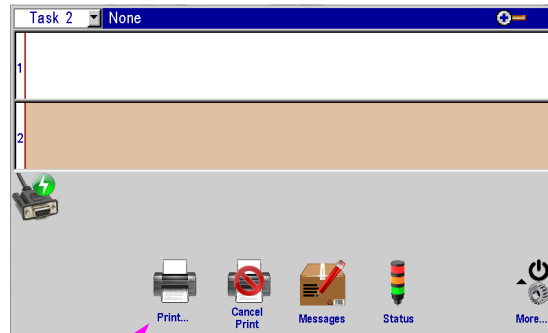

Print Button

Select the desired message to print, and press the **Print** button.

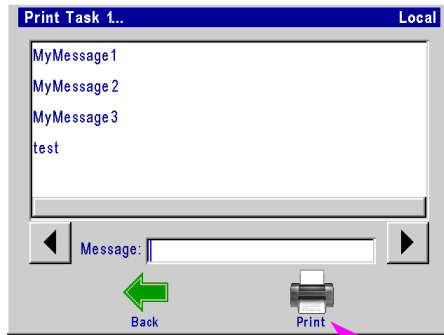

Print Button

The message will print on the next photocell trigger.

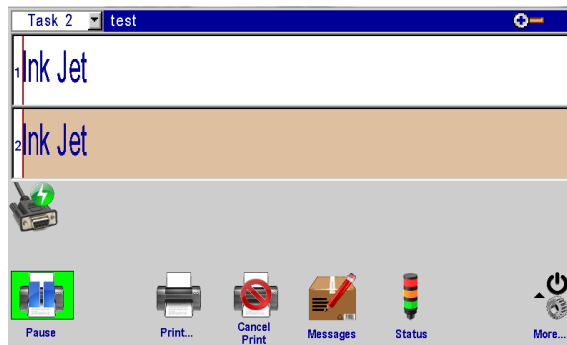

Section 3: User Interface

On-Screen Keyboards & Numeric Keypads

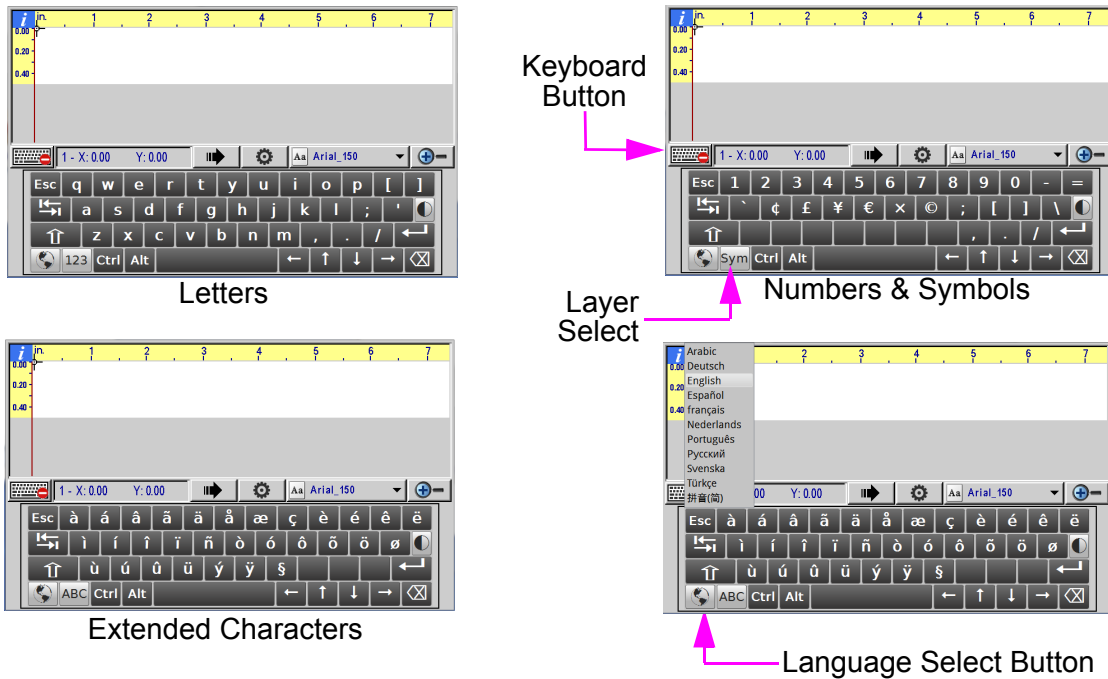

Keyboard Button:

- Edit Screen only: Press once to show the keyboard; press again to hide it.
- All other screens and dialogs: Keypad or keyboard appears when text or numeric input box is touched.

Layer Select:

- Pressing the **Layer Select** button cycles through; letters, numbers & symbols, and extended characters.

Language Select Button:

- Changes keyboard layout to that of the language selected. Changes keyboard layout only; user interface language does not change.

ESC (Escape):

- Undoes any changes made to any input entry box. If no changes made, hides the keypad or keyboard.
- Edit screen full keyboard: always hides the keyboard.

Arrow Keys:

- Moves highlighted fields or the cursor around in the Message Editor.

Tab:

- Shifts focus between fields in the Message Editor.

Backspace:

- Deletes the character to the left of the cursor.
- On the edit screen, deletes a highlighted (red) field.

Ctrl (Control) in Message Editor:

- Amplifies the movement of the arrow keys.
- Press **Ctrl-Enter** to insert a new line in a text field.

Shift:

- Press **Shift** once to make the next character upper case.
- Press **Shift** twice for shift lock. Press **Shift** again to exit shift lock.

Home Screen:

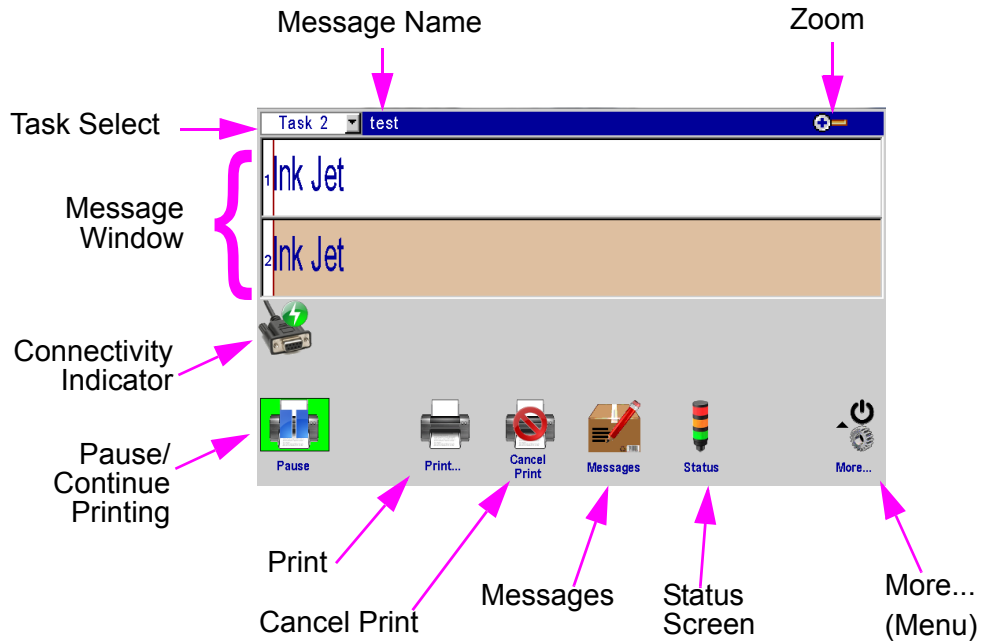

Message Window:

- Displays the current print message
- Updated approximately every seven seconds, so every print may not be displayed.
- Touch and swipe the **Message Window** to scroll the message.
- White or Beige bars represent the print heads. The numbers in the left margin correspond to the numbers assigned to the print heads during system setup.
- The window header displays the task number and the file name of the message being printed. "None" is displayed when no message is being printed.

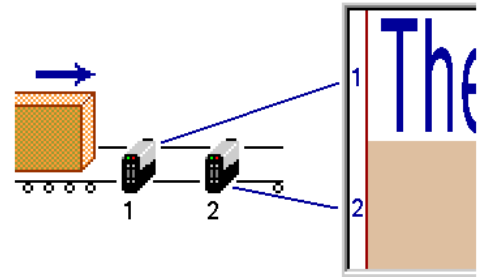

Task Select Drop Down List:



- On dual task systems, switches controller operation from one task to another.

Pause/Continue Button:



- Button appears only when a print message is displayed in the Message Window.
- Press **Pause** to halt printing. Any message being printed will finish before printing is halted.



- Press **Continue** to resume printing. Print will resume on the next photocell trigger.



Print Button:

- Press **Print** to select a message to print.
- Select the desired message and press the **Print** button. The message will print at the next photocell trigger.



Cancel Print Button:

- Press the **Cancel Print** button to remove the current message from the print head(s) and stop print.



Connectivity Indicator:

- Indicates the controller is electronically connected to and communicating with the print heads.



- Indicates the controller is electronically disconnected and is not communicating with the print heads.



Status Button:

- Press the **Status Button** to display the Status Screen. The Status Screen displays:
 - Controller firmware version number.
 - Fonts and Logos present on the selected print head.
 - Product Detect status.
 - Printing status. Indicates the presence of a print message on the selected print head.
 - Ink Type, if applicable.
 - Current Date and Time, as reported by the selected print head's clock.
 - Print head firmware version number.

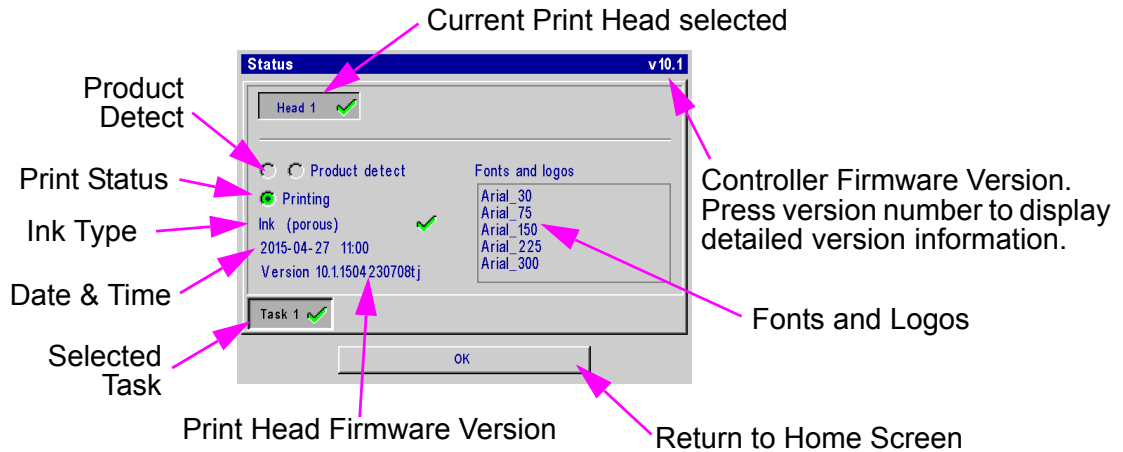
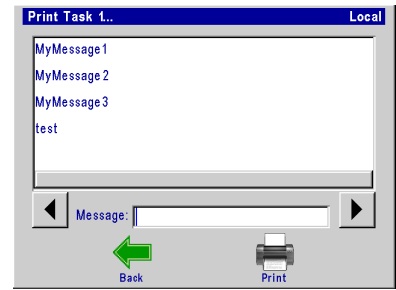

Zoom:

- Expands the message window to full screen and magnifies the print message so that fine details may be seen.
- Press once to zoom in; press again to zoom out.



More... Menu Button:



(See "The Apps Screen" on page 24.)

Fires all jets for a short period of time on the selected print head.

(See "Step 7: Configure the Print Head" on page 10.)

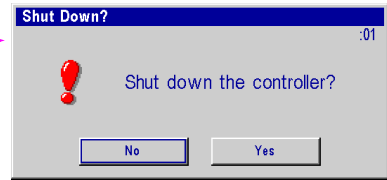

To turn the controller on, touch anywhere on the touchscreen.

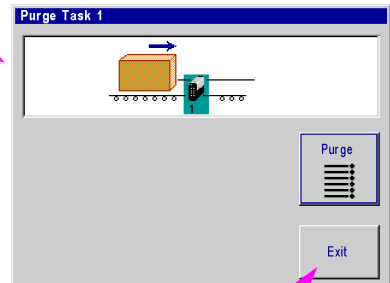
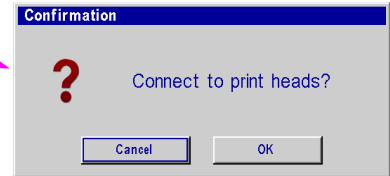

Returns to Home Screen

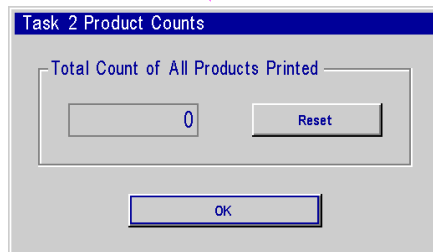

Displays count of all products printed.

Message Editor



Message Button:

- Press the **Message Button** on the **Home Screen** to bring up the message screen.
- To create a new message press the **New** button.
- To edit an existing message, select the message and then press the **Open** button.
- Both editing a message and creating a new message will bring up the message editor.

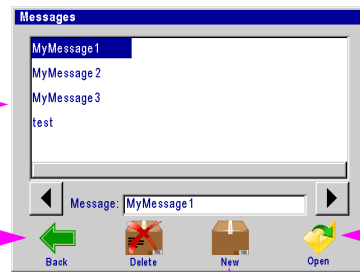
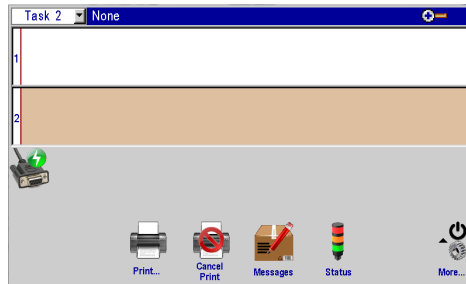

Back → Delete Message → New Message → Open

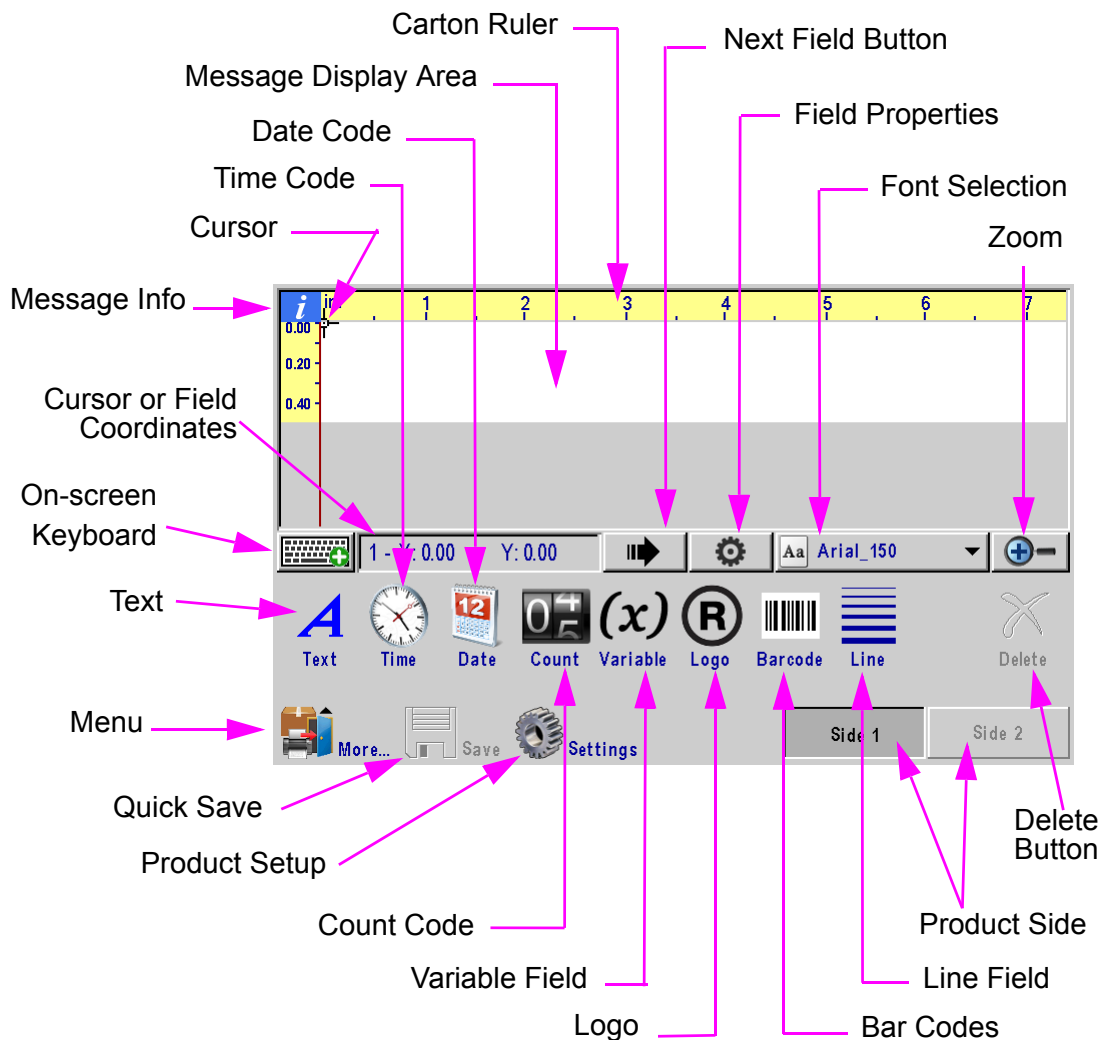

Time, Date, and Count Codes

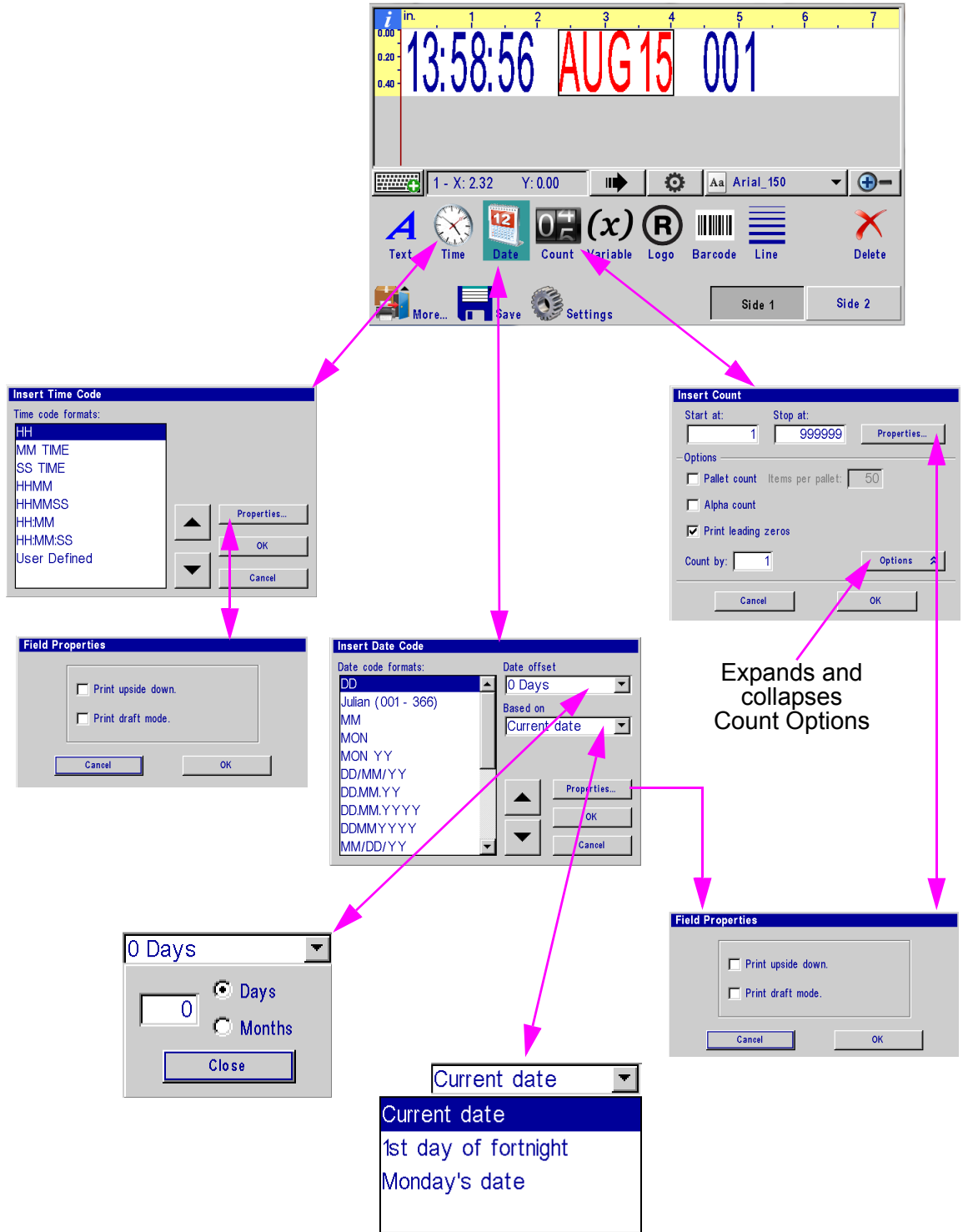

User Defined Time Codes

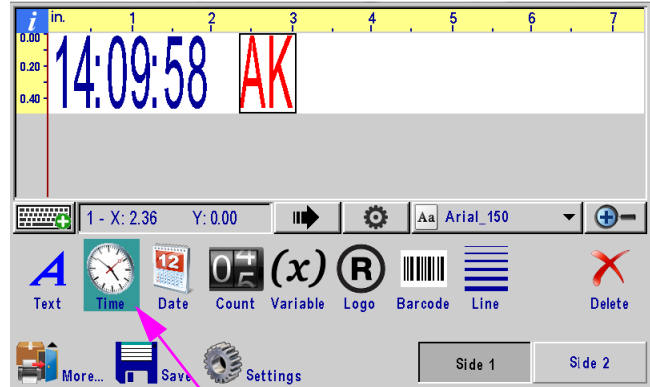

When **User Defined** is selected, **Define Time Code** button appears.

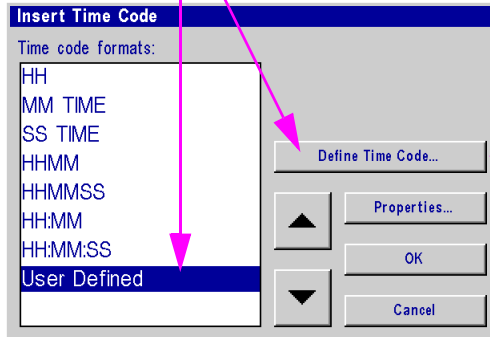

Sequential format: minute code shown. Minute 00 = AA, 01 = AB, 02 = AC, etc.

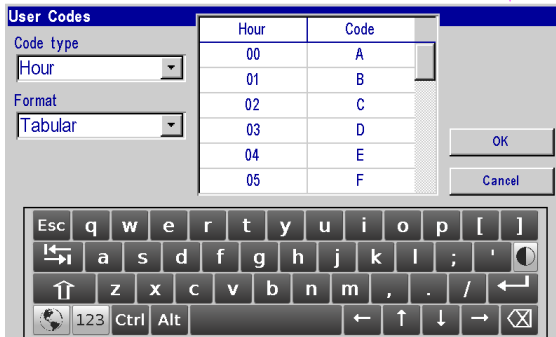
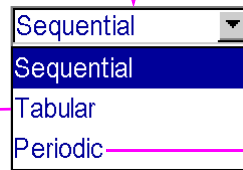
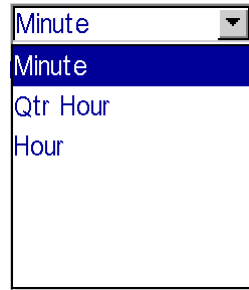
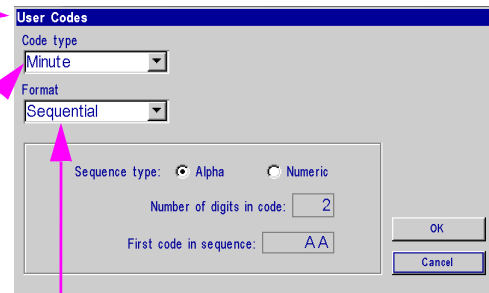

Tabular format: codes printed taken from table. Use default codes (default Hour codes shown) or edit table to suit your requirements.

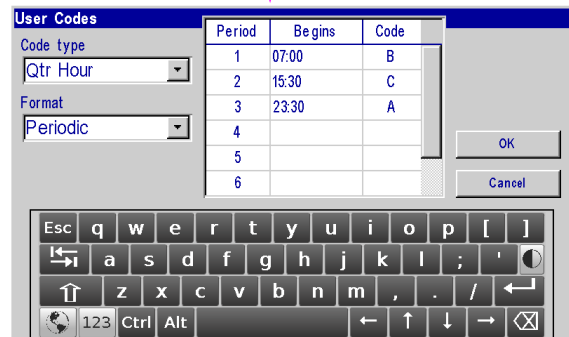

Periodic format: example above illustrates a shift code implemented by using a periodic quarter hour code. 'A' prints from 23:30 - 06:59, 'B' from 07:00 - 15:29, and 'C' from 15:30 - 23:29.

User Defined Date Codes

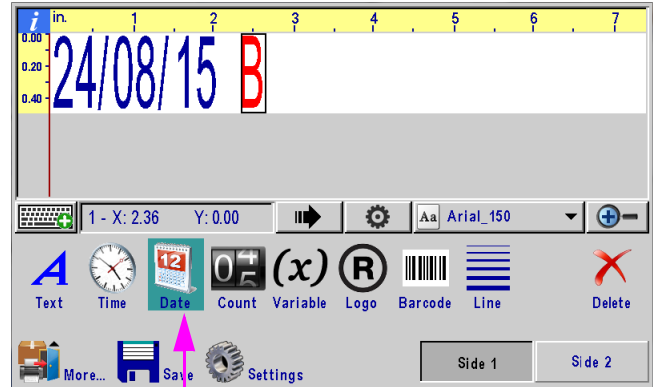

When **User Defined** is selected, **Define Date Code** button appears.

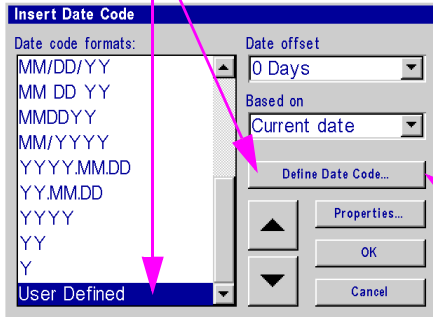

Sequential format: minute code shown. Day 1 = A, Day 2 = B, Day 3 = C, etc.

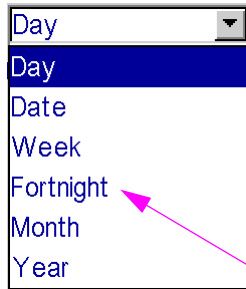
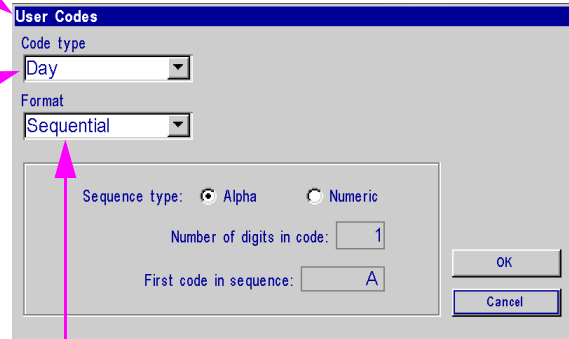

The Fortnight code type is available for the Tabular format only.

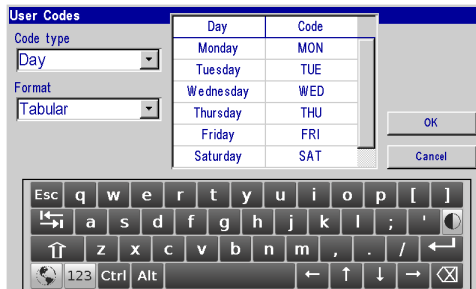
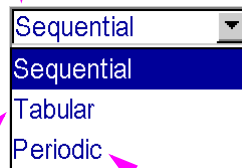

Tabular format: codes printed taken from table. Use default codes (default Day codes shown) or edit table to suit your requirements.

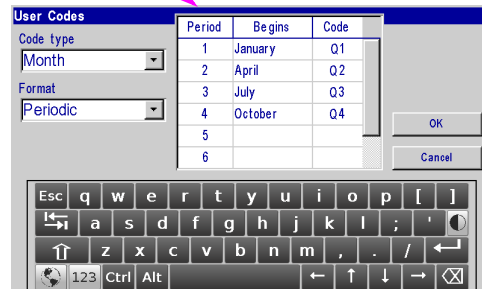

Periodic format: example above illustrates a quarter year code implemented by using a periodic month code. 'Q1' prints from Jan 1 - Mar 31, 'Q2' from Apr 1 - Jun 30, etc.

Product Counts, Variable Fields, Logos

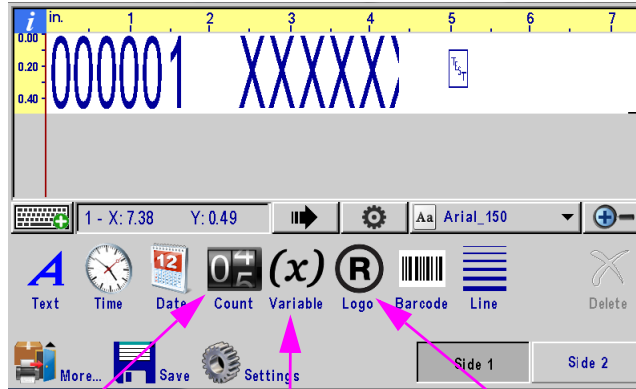

Scroll through logo images or select from list

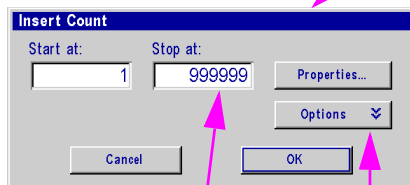

Maximum 9-digit count

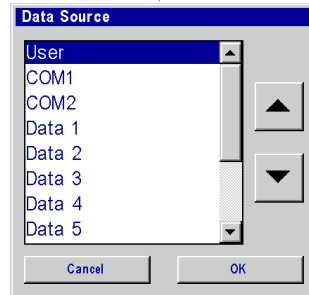
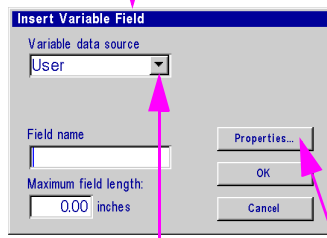

Variable Field Data Source

User: Print data entered when print message containing the variable field is selected to print.

COM1, COM2: Data is received through COM1 or COM2 serial port. Data must be received before the message is selected to print.

Data 1-10: Data is retrieved from corresponding system variable. User has the option to change the data when the message is selected to print.

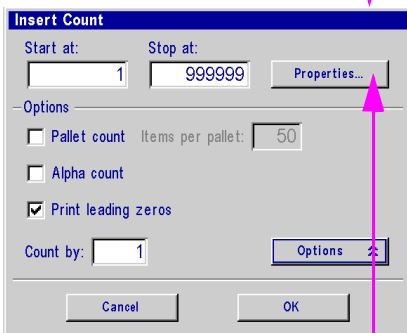
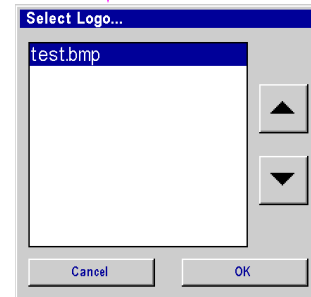
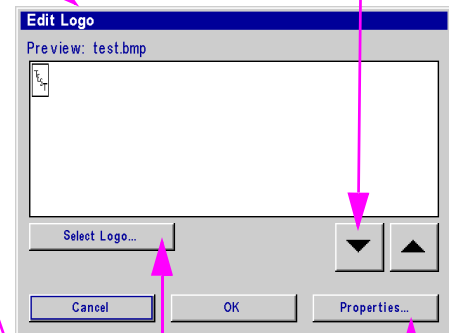

Incrementing Count

Count increments when the 'Start at' value is less than the 'Stop at' value.

Decrementing Count

Count decrements when the 'Start at' value is greater than the 'Stop at' value.

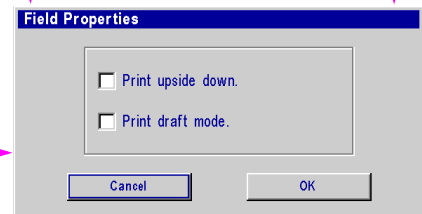

Barcodes, Lines, Product setup, & Menu

Reverts message to the last saved

Clears contents of message editor

Calculates estimated ink usage for the contents of the editor

Exits the editor to the home screen

Prints the contents of the editor on the next photocell trigger

Quick save of current message

Increase or decrease barcode height

Increase or decrease barcode width

Increase or decrease value of selected property

Enter line height and width

Product Setup

Length: 12.00 in. Left margin: 0.00 in.

Character width: 100% Character spacing (columns): 3 columns

Side 2 = side 1. Task 2 = task 1. Print upside down. Repeat print at 12.00 in. intervals. Print n times: 1 Prompt

Bar Code Type

- GTIN-12 (UPC-A)
- UPC-E
- GTIN-13 (EAN-13)
- GTIN-8 (EAN-8)
- Code 39
- GTIN-14 (ITF-14)
- GTIN-14 (UCC-128)
- Code 128

Insert Bar Code

Code Type: Data Source: Insert

Bar code data: 12345678901

GTIN-12 (UPC-A) Source: Fixed

Data Source

- Fixed
- User
- COM1
- COM2
- Data 1
- Data 2
- Data 3
- Data 4

Bar Code Properties

20 115 0 0 5

Select a property above.

- +

Human readable: Arial_30

Edit Block or Line

Dimensions (in.)

0.10 2.00

7 8 9 Esc
4 5 6
1 2 3
0



Message Info Box

Task number & message name

Estimated prints per ink cartridge

Product length & left margin settings

Zoom



- Increases message size



- Returns message to original size



Delete Button

- Deletes the selected field.

Direct Entry of Cursor or Field Position

Direct Entry Box

Field: selecting the Direct Entry Box while having a field selected will allow the user to manually input the X & Y location of the selected field

Cursor: When no fields are selected the Direct Entry Box will allow the user to manually input the X & Y location of the cursor

Print Head Number

The Apps Screen

See "Time, Date, and Rollover Time Screen" on page 25

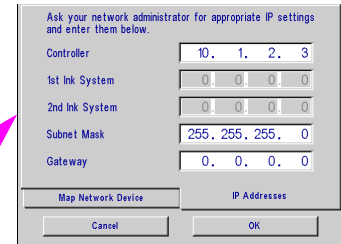
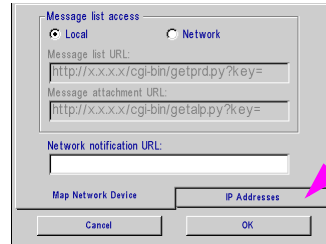
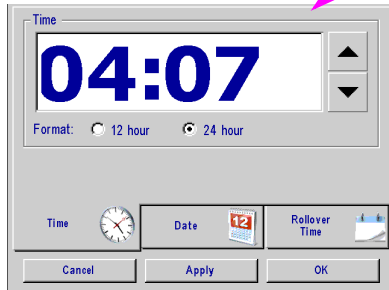

Return to the Home Screen

Network Settings

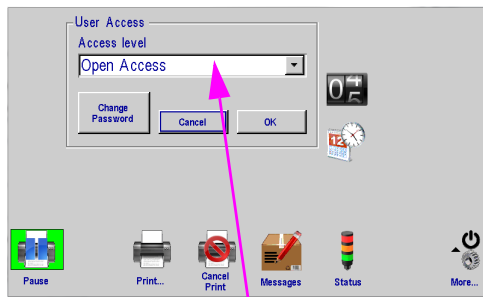
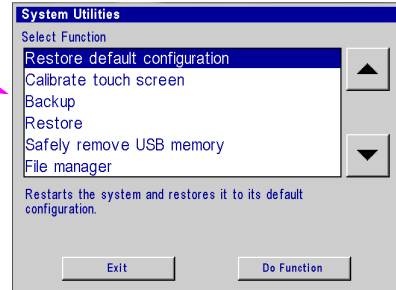
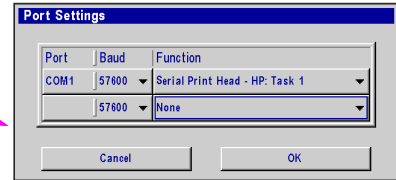
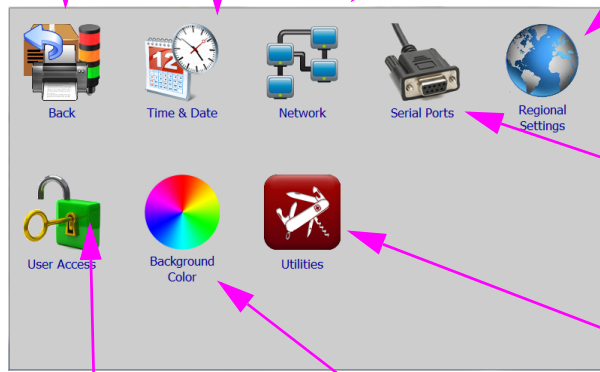
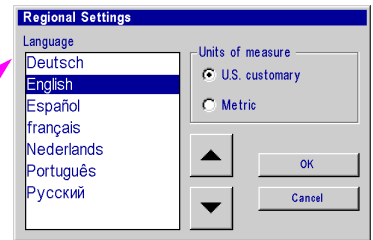

See "User Access" on page 25

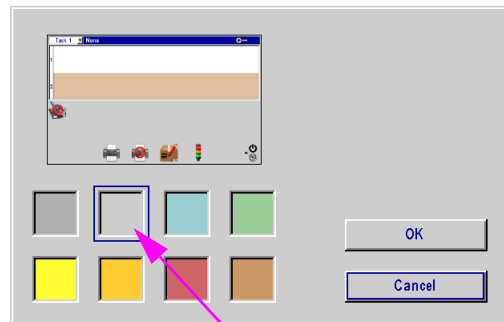

Select Background color

Time, Date, and Rollover Time Screen

Set the controller's time and time format

NOTE: The 12 hour/24 hour format option applies to controller functions; it does not apply to time codes in print messages.

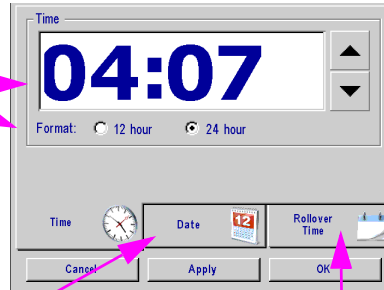

Press "OK" to return to the Apps Screen

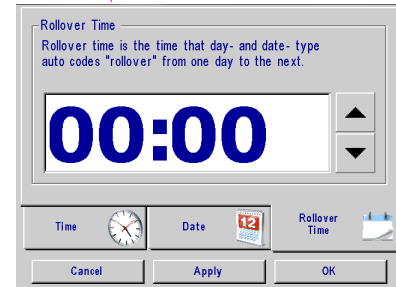

User Access

Controls within this box set the user access level. Buttons outside the box mirror the Home Screen and indicate which functions are password protected and which are open.

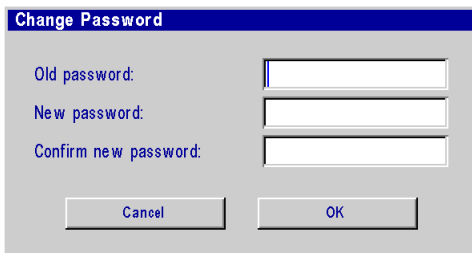
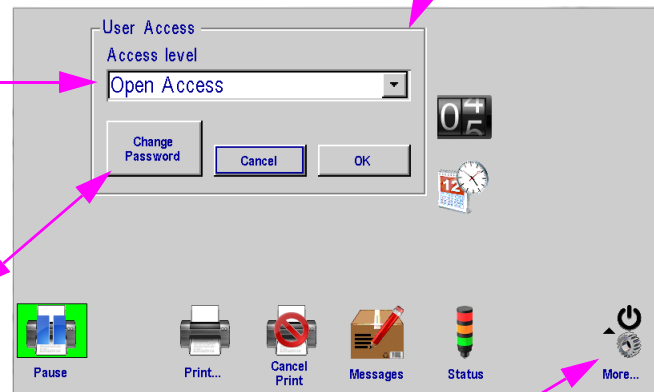
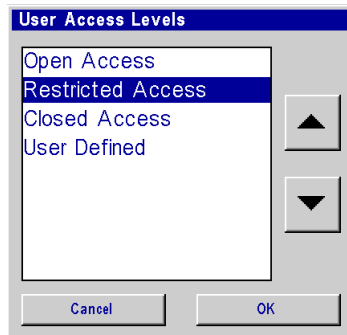

Padlock symbol indicates function is password protected.

The factory set password is **Manager**. Passwords are case sensitive.



Note: Users can either select a pre-defined access level from the list, or they can select "User Defined" and customize their permissions by touching icons on the User Access screen.

Section 4: Maintenance & Shutdowns

Pen Cartridge Maintenance

Porous Inks:

- **Daily Maintenance:** Prior to shift startup, the cartridge orifice array should be cleaned of any debris or ink build up. See Daily maintenance procedure.
- **Shutdowns of one day or more:** for extended shutdowns, follow the daily maintenance procedure, remove the pen cartridge from the print head and store in a cartridge boot cap (5780-208).
- **Bulk Ink System:** a properly maintained bulk ink pen cartridge can maintain acceptable print quality for up to one 350ml ink cartridge. However, there are several factors that can affect print quality:



- A. **The amount of time it takes to consume 350ml of ink:** The longer it takes to consume 350ml of ink the more difficult it is to maintain acceptable print quality. Bulk ink is designed for high throughput applications and is not suitable as a means of reducing ink cost in low throughput application. If ink cost is an issue then consider printing in draft mode. Draft mode produces a lighter mark but the resulting ink cost is comparable to using a bulk ink system.
- B. **Daily maintenance:** If daily maintenance isn't performed, then print quality will degrade before 350ml of ink has been consumed.
- C. **Capped during shutdowns:** If the cartridge is not properly capped during down times, then print quality will degrade over time.
- D. **Environmental conditions:** Hot and/or dry environments are the most challenging to maintain print quality. This is due to low humidity pulling solvent out of the ink, which leads to a hard plug in the nozzle. No amount of purging or wiping can recover a hard plug. To combat this scenario, the pen cartridge must be capped during down times.
- E. **Air currents around the print head:** Air flow across the front of the print head can contribute to ink drying in the nozzles.

Non-Porous Inks:

- **Daily maintenance:** prior to shift startup, the cartridge orifice array should be cleaned of any debris or ink build up. See Daily Maintenance procedure.
- **Shutdowns of one hour or more:** For short term or extended shutdowns, follow the daily maintenance procedure, remove the pen cartridge from the print head and store in a cartridge boot cap (5780-208).
- **Leading edge print quality:** Poor print quality on the leading edge of print can be a result of the fast drying qualities of non-porous ink. This is caused by the shortened decap time associated with non-porous ink. To resolve this issue two or more primer bars (lower case L's) should be placed at the leading edge of the print message. This will prime the print cartridge so the necessary message content has acceptable print quality.

Daily maintenance procedure

Requirements:

- Deionized or distilled water (DO NOT USE TAP WATER) for **POROUS INK ONLY**
- Sponge Swabs (p/n: 5760-832)

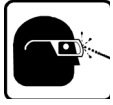

Procedure:

- For **POROUS INK ONLY**, lightly dampen sponge swab with deionized water.
- For **NON-POROUS INK ONLY**, hold sponge swab against orifice array of cartridge. Press and hold the purge button on the rear of the print head for at least ten seconds. This will fire all channels of the ink cartridge and dampen the swab with ink. The ink will act as its own solvent for cleaning.
- Rub up and down across the orifice face with light force several times with one side of the sponge swab.
- Turn the swab over and make one final light rub stroke top to bottom.
- Immediately press and hold the PURGE button on the rear of the print head for 5-10 seconds to re-prime the orifices. Because ink will eject during the channel purging, a piece of paper, cloth, or comparable material can be held in front of the orifice array.



Do NOT hold the ink catch material against the orifice array as print quality will be degraded.

- If print quality becomes unsatisfactory during any shift repeat this procedure.

Before cleaning

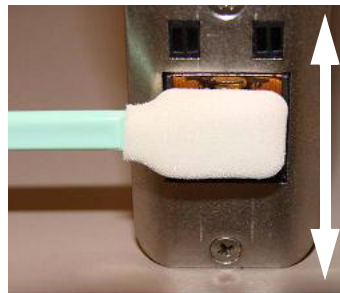

Wipe pen cartridge face up and down several times. Immediately press and hold the purge button for 5-10 seconds.

After cleaning

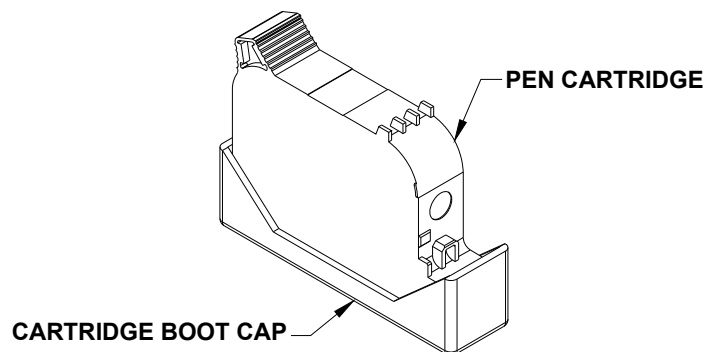

Section 5: Troubleshooting

NO PRINT

System Symptom	Possible Cause	Actions
No print head power / green LED on rear of print head	<ul style="list-style-type: none"> Power Supply AC Source 	<ul style="list-style-type: none"> Check power supply light indicator. Check for AC power source between power supply input limits.
PURGE button on rear of head does not appear to work	<ul style="list-style-type: none"> Ink cartridge is damaged or empty Print head Board 	<ul style="list-style-type: none"> Replace with new cartridge and repeat PURGE. Replace print head printed circuit board or print head.
Print head purges but won't print desired message	<ul style="list-style-type: none"> Loose or missing cables Controller or PC software not configured for Serial Print Head Encoder Malfunction Product not triggering photocell. 	<ul style="list-style-type: none"> Tighten or install all cables. Ensure print heads are configured as serial. See "Section 2: Quick Start", "Step 6: Cabling, Power, and Serial Port Setup" on page 7. Ensure encoder is installed and plugged into the last print head in the daisy chain. Ensure the product is within 1/4" of the front face of the print head. If an external photocell is installed, then validate the setting from the Control Panels, System Setup, Task Options tab.

POOR PRINT QUALITY

System Symptom	Possible Cause	Actions
Print is foggy or light	<ul style="list-style-type: none"> Print head is mounted greater than an 1/8" away from the substrate There are large air currents near the print head 	<ul style="list-style-type: none"> Adjust the print head according to "Section 2: Quick Start", See "Step 4: Adjust Print Head to Substrate" on page 5. Locate print head in an area where there are minimal currents or provide wind barriers.
Print image is missing channels or has multiple fractures	<ul style="list-style-type: none"> Pen cartridge face is dirty Pen cartridge face is damaged at the orifice array Pen cartridge is not properly seated in the print head 	<ul style="list-style-type: none"> Clean the pen face per "Daily maintenance procedure" on page 27. Replace damaged pen cartridge with new. Remove cartridge and reinsert.
Print that appears smeared and/or debris is building up on the pen cartridge.	<ul style="list-style-type: none"> Carton rubbing across the front of the print head 	<ul style="list-style-type: none"> Adjust print head distance or/and use roller retracting bracketry to insure print head maintains proper distance to prevent damage to pen cartridge.
Unable to recover missing channels and print quality.	<ul style="list-style-type: none"> Damaged cartridge Poorly seated pen cartridge. Inadequate cartridge maintenance. 	<ul style="list-style-type: none"> Replace pen cartridge. Remove pen cartridge, clean pads of pen cartridge and pogo pins in print head. Re-insert cartridge. When a cartridge is not properly cleaned or capped during down times the solvent in the nozzles evaporate and can create a hard plug. Once a hard plug has formed it is impossible to clear and the cartridge needs to be replaced.

PRINT HEAD LED FUNCTIONALITY

System Symptom	Possible Cause	Actions
Red LED on steady	<ul style="list-style-type: none">• Pen cartridge ink level is low.	<ul style="list-style-type: none">• Ready the next pen cartridge for installation.
Red LED is flashing slowly	<ul style="list-style-type: none">• Pen cartridge is out of ink and significant print degradation is imminent.• A non-recognized cartridge is installed.	<ul style="list-style-type: none">• Prepare to install a new pen cartridge.• Install an original recognized cartridge.
Red LED is flashing fast	<ul style="list-style-type: none">• Pen cartridge is missing from print head stall.• Print head is calibrating a new cartridge.• Print head is in thermal protection mode.	<ul style="list-style-type: none">• Install or re-install the appropriate pen cartridge.• Allow the print head up to 30 seconds to calibrate a new pen cartridge.• Pen cartridge is out of ink and the print head is self-protecting against excessive heating. Replace the appropriate pen cartridge.

Appendix A: Specifications

1/2" Print Head:

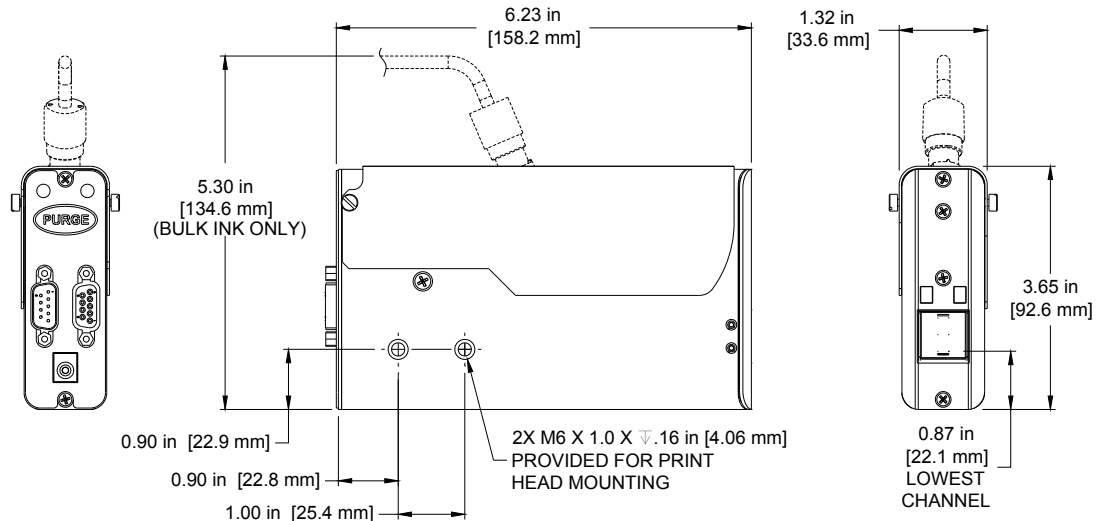

Weight: 1.3 lbs (.6 kg)

Enclosure: Anodized Aluminum and Stainless Steel

Electrical:

15 VDC from power supply to print head

Power Supply: 90-260 VAC, 50/60 Hz, 1.5 A max. (per power supply)

Print Speed: 200 fpm, 300 dpi continuous

Print Resolution: 300 dpi

Throw Distance:	Porous Ink	Non-Porous Ink
Recommended Gap:	.1 in (2.5 mm)	.08 in (2.0 mm)
Maximum Gap:	.25 in (6.3 mm)	.15 in (3.8 mm)

Print Head Orientation: From horizontal to straight down.

Print Head Tilt:

+/- 45° from vertical for standard print cartridge

+/- 90° from vertical for Bulk Ink print cartridge

Number of Print Fields:

Maximum 5 lines of print per print cartridge at any given point. Each print line may have at most three (3) 52-character print fields; number of fields per line increases as the number of characters per field decreases.

File Storage:

Twenty-seven 256kB sectors per print head are available for font and logo file storage. Files larger than 256kB use multiple sectors. Factory installed fonts occupy 8 of the 27 sectors.

Five factory installed fonts: Arial 30, 75, 150, 225, and 300 (0.1 in / 2.54 mm, 0.25 in / 6.35 mm, 0.5 in / 12.7 mm, 0.75 in / 19.05 mm, 1.0 in / 25.4 mm).

Bitmap (logo) files: 150 dots tall max (.5 in / 12.7 mm); 32,767 columns wide max (109 in / 2.79 m at 300 dpi).

Environment:

Ambient operating temperature: 50°F to 104°F (10°C to 40°C); operating humidity: 10% - 80% RH

Ink Type: Dye, Pigmented, or Solvent base hp 45 cartridges

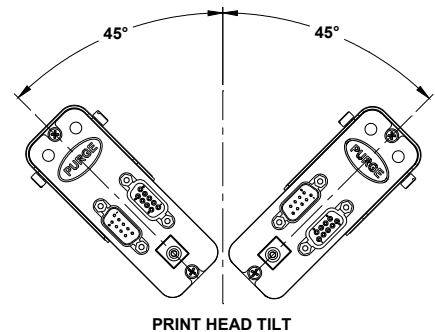

1" Print Head:

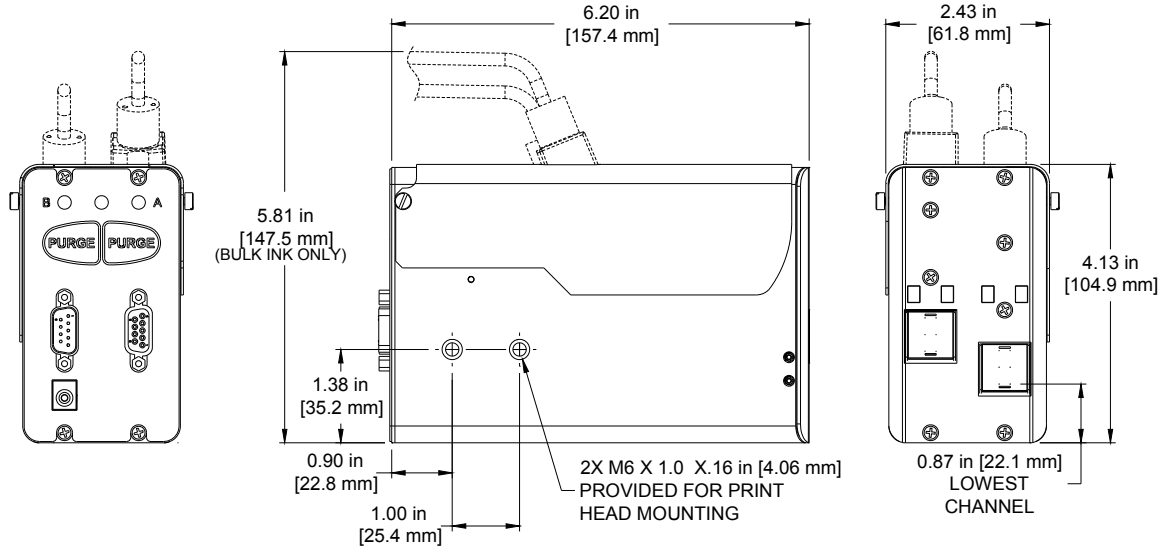

Weight: 2.1 lbs (1.0 kg)

Enclosure: Anodized Aluminum and Stainless Steel

Electrical:

15 VDC from power supply to print head

Power Supply: 90-260 VAC, 50/60 Hz, 1.5 A max. (per power supply)

Print Speed: 200 fpm, 300 dpi continuous

Print Resolution: 300 dpi

Throw Distance:	Porous Ink	Non-Porous Ink
Recommended Gap:	.1 in (2.5 mm)	.08 in (2.0 mm)
Maximum Gap:	.25 in (6.3 mm)	.15 in (3.8 mm)

Print Head Orientation: Horizontal to straight down.

Print Head Tilt:

+/- 45° from vertical for standard print cartridge

+/- 90° from vertical for Bulk Ink print cartridge

Number of Print Fields:

Maximum 5 lines of print per print cartridge, 10 total for the print head, at any given point. Each print line may have at most three (3) 52-character print fields; number of fields per line increases as the number of characters per field decreases.

File Storage:

Twenty-seven 256kB sectors per stall are available for font and logo file storage. Files larger than 256kB use multiple sectors. Factory installed fonts occupy 8 of the 27 sectors.

Five factory installed fonts: Arial 30, 75, 150, 225, and 300 (0.1 in / 2.54 mm, 0.25 in / 6.35 mm, 0.5 in / 12.7 mm, 0.75 in / 19.05 mm, 1.0 in / 25.4 mm).

Bitmap (logo) files: 300 dots tall max (1.0 in / 25.4 mm); 32,767 columns wide max (109 in / 2.79 m at 300 dpi).

Environment:

Ambient operating temperature: 50°F to 104°F (10°C to 40°C)

Operating Humidity: 10% - 80% RH

Ink Type: Dye, Pigmented, or Solvent base hp 45 cartridges

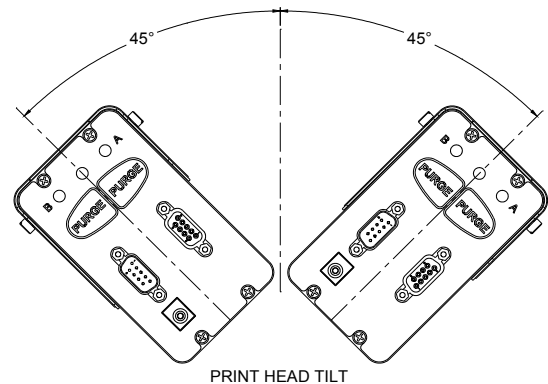

Bulk Ink Supply:

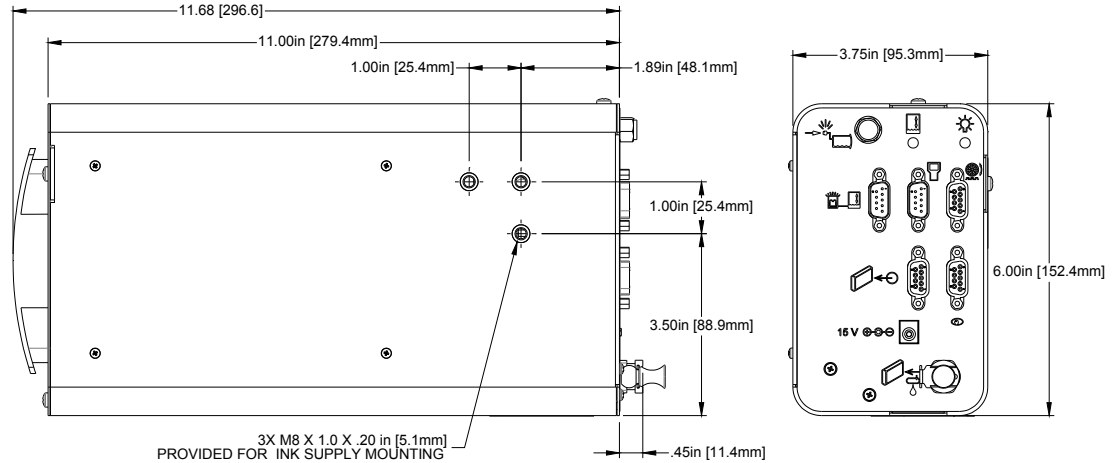

Weight

4.2 lbs (1.9 kg) without ink cartridge

5.4 lbs (2.5 kg) with ink cartridge

Enclosure

Powder-coat painted steel

Mounting

Modular brackets included

Electrical

15 VDC from power supply to print head

Power Supply: 90-260 VAC, 50/60 Hz, 1.5 A max. (per power supply)

Normal Operating Pressure Range

4 psi to 5 psi

Cable Ports

- (1) 15 VDC power supply jack
- (1) Handheld controller connector
- (1) Print head connector
- (1) Photocell connector
- (1) Encoder connector
- (1) Beacon connector

Plumbing Port

- (1) Pressurized ink outlet to print heads

Environment

Ambient operating temperature: 50°F to 104°F (10°C to 40°C)

Operating Humidity: 10% - 80% RH

Tubing Limitations

Maximum horizontal tube length = 10 ft (3 m)

Maximum vertical tube length = 3 ft (1 m)

Print Head Limitations

One daisy chain per Bulk Ink Supply; each daisy chain may have up to 8 print head cartridge stalls (eg: eight 1/2" Print Heads; four 1" Print Heads; four 1/2" Print Heads with two 1" Print Heads)

Ink Type

Dye base

Handheld Serial Controller

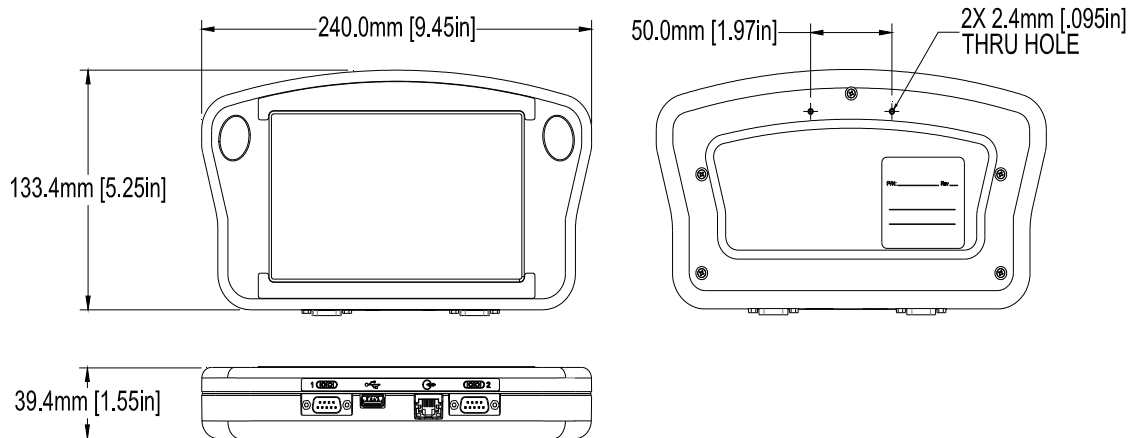

Size

Weight: .50kg [1.1lb]
Height: 133.4mm [5.25in]
Width: 240.0mm [9.45in]
Depth: 39.4mm [1.55in]

Enclosure

Black ABS Plastic

User Interface

Type: Graphical User Interface
keyboard: on screen QWERTY

Display

7in [178mm] LCD with touch screen,
800 X 480 pixels

Fonts

Unicode

Storage

512 MB flash memory

Ports

(2) RS-232 Ports, (1) USB Port
(1) 100 base-T Ethernet Port

Electrical

15 VDC Supplied from print head power supply: 90-260 VAC, 50/0 Hz, 1.5A max.

Environment

Ambient operating temperature: 40°F to 104°F (5°C to 40°C)
Operating humidity: 10% - 90%, non condensing

System Interconnect Diagram
Handheld Controller CPU Board

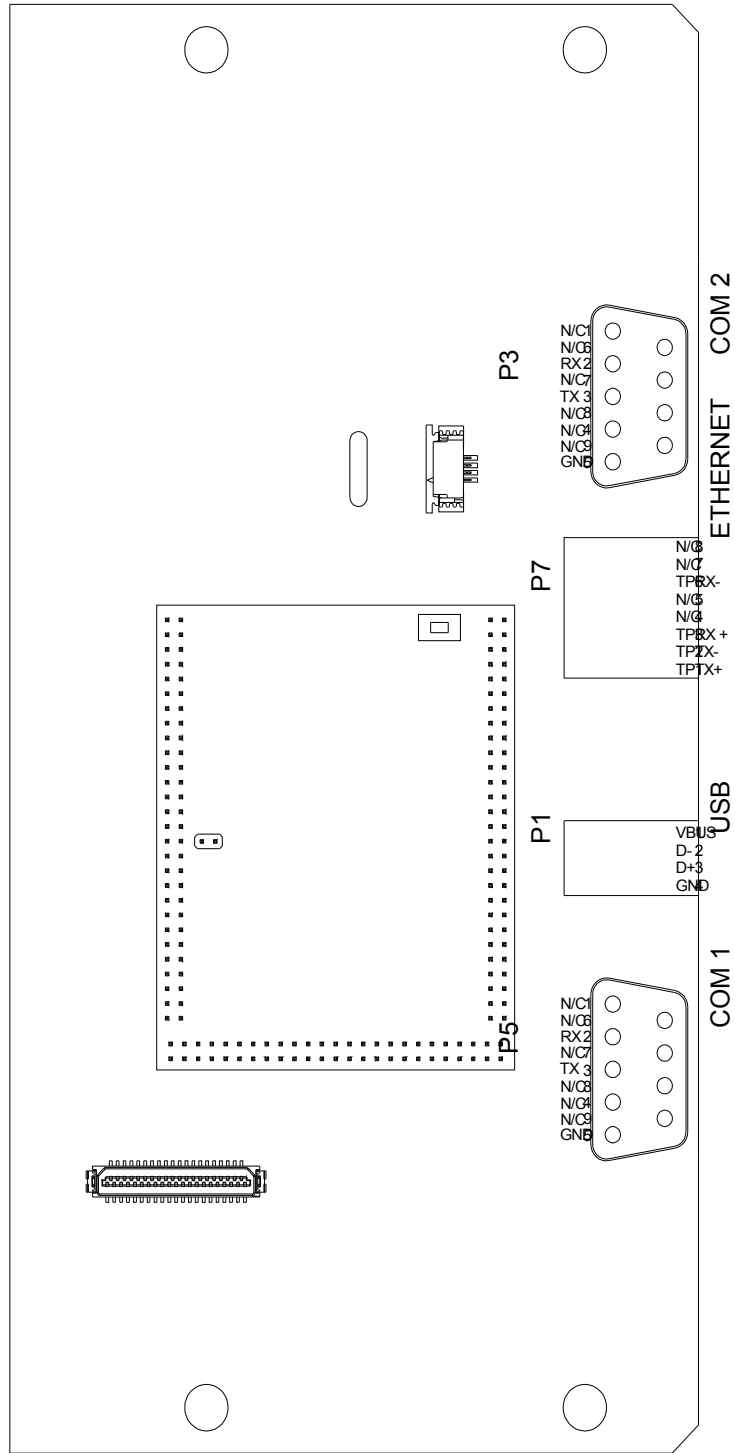

Appendix B: Theory of Operation

Thermal Jet Print Heads

TIJ Technology

The print head uses Thermal Ink Jet (TIJ) technology as implemented on the hp® 45A cartridge. TIJ technology works by rapidly heating the ink. As the ink heats it expands and is ejected from the print cartridge orifices. Because the individual orifices are very small, many more can be compacted in the same amount of space as conventional print technologies. With more orifices per vertical inch / millimeter, a much higher resolution image can be produced.

Similarities and Differences

A print head can operate stand-alone or in concert with other print heads connected one to another in a daisy chain configuration. Up to eight 1/2" Print Heads or four 1" print heads can be daisy chained. Print heads can be controlled by the Handheld controller, from a PC or laptop using the included InkJet Demo software interface program, or by a user developed application.

Print heads can print up to five lines of print, using any combination of the various print field types supported, including fixed text, date/time codes, product counts, variable fields, logos, and a variety of bar codes, including Data Matrix 2-D codes.

Unlike other inkjet technologies, these print heads store and process the currently printing message internally. This allows the print heads to be disconnected from the controlling device and operate "stand alone" once the print information has been uploaded to the heads. However, print head and print message status is unavailable to the the controlling device once the print heads are disconnected.

Ink Cartridge Ink Status

Each ink cartridge contains approximately 42 mL of ink and has been programmed to make full use of the **Smart Level Ink Detection System**. When a new cartridge is snapped into a print head it is given an identity code so that its ink level may be monitored. As the ink depletes to 10% ink remaining, an "Ink Low" condition occurs and the red LED on the rear of the print head turns on steady. The red LED changes to slow flashing, indicating "Ink Out", when there is minimal ink remaining, and significant print degradation is imminent. Ink status is reported back to the Handheld controller or InkJet Demo software as long as they are connected to the print head daisy chain.

Handheld Controller

Functional Description

The Handheld and Thermal Jet System prints text, autocodes (such as product counts or time and date stamps), bar codes, and/or graphics onto products as they travel by conveyor past stationary print heads. Print can be on any one of, or a combination of, the product's sides. Print speed is controller by a conveyor mounted encoder or a built-in fixed speed encoder. Products are detected using a photosensor. A graphical user interface with color LDC, touch screen, and on-screen keypads provides for easy and intuitive system operation.

Power

The Handheld Controller draws its power through either one of its two serial port connectors from the print head directly attached to the connector, or in applications where the optional accessory hub or Bulk Ink System is used, from the hub or ink system.

Battery Backup - A 3V battery on the CPU Board maintains the contents of system SRAM and keeps the real time clock running during power outages or when the Handheld controller is not plugged into a power source.



Please note that power is applied to the Handheld even when it is "turned off." When turned off, the controller enters a sleep mode where it responds to nothing but a touch-screen touch. All voltages are present while sleeping. The only way to completely remove power is to unplug the unit.

Handheld Controller Power & Cabling Diagrams

Single Task: The Handheld controller draws its power from the print head, and the COM1 port is connected to the output connector of the last head in the daisy chain.

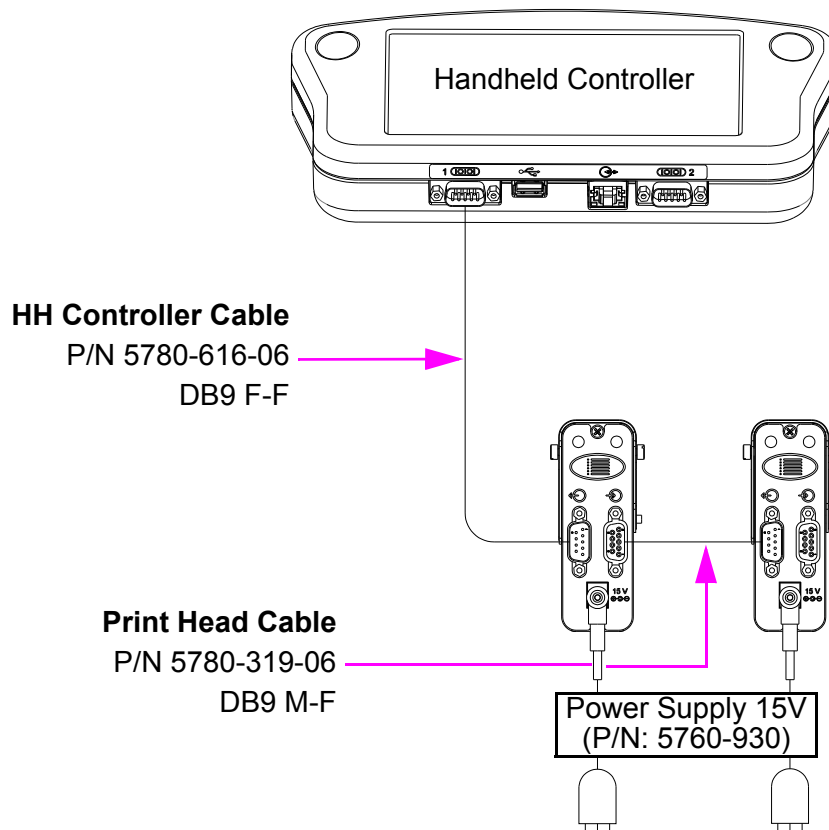

Single task with accessory hub: The Controller draws its power from the accessory hub, and is plugged into the 'handheld' connector on the accessory hub; the accessory hub is plugged into the output connector of the last print head in the daisy chain.

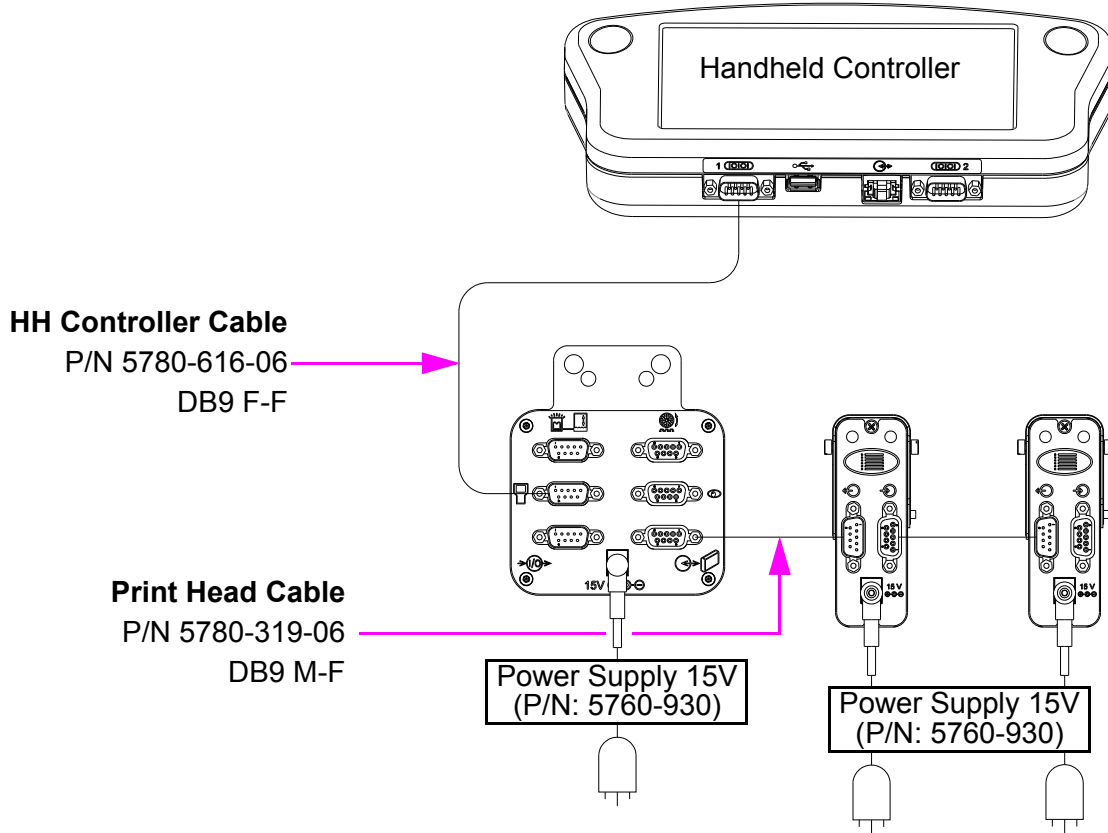

Appendix C: File Backup and Restore

From a PC

Use these procedures for making archival copies of the system configuration and print message files, and for preserving the system's configuration and print messages during firmware upgrades. File types saved during a backup are .cfg, .prd, .bmp and .alp. These are the system configuration files, message files, logo files and label files, respectively.

These instructions assume the Handheld Controller is already connected, via Ethernet, to a PC. If not, please refer to "Appendix D: Configuring a PC to Communicate with the Handheld" on page 42.

1. Obtain the Controller's IP address. Most controllers have an IP address of **10.1.2.3**. It may be different if the controller is networked with other Handhelds or other devices. If the IP address is unknown, go to the controller, and from the **Home Screen**:
 - Open the menu and touch the **Apps** button to go to the Apps Screen.
 - Touch the **Network** button on the Apps Screen to open the Network Setup Screen.
 - Touch the **IP Addresses** tab to display the system's IP addresses.
 - Record the Controller's IP address (it's the top one).
2. On the PC, start Microsoft Internet Explorer (must be version 3.2 or higher) or another web browser.
3. In the browser's address box type in "http://", followed by the controller's IP address. See the illustration below:

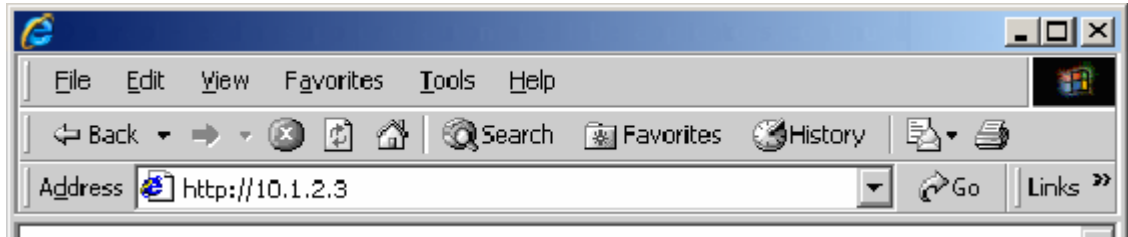

4. Press **Enter**. The web page shown below should appear.

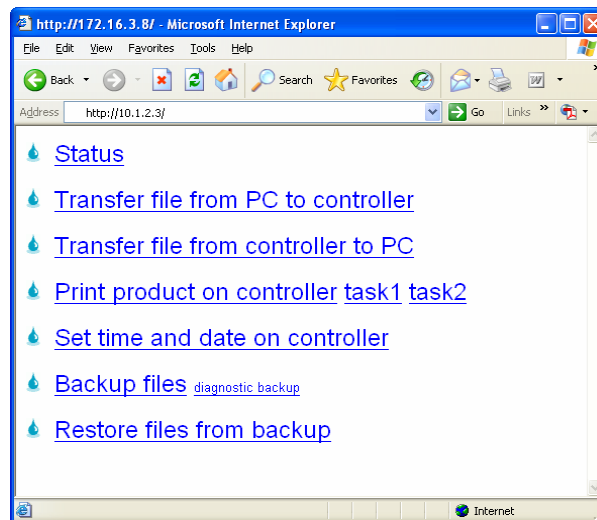

File Backup

To backup the system files, click the **Backup files** link. The dialog box shown at right (or a similar dialog box) will appear.

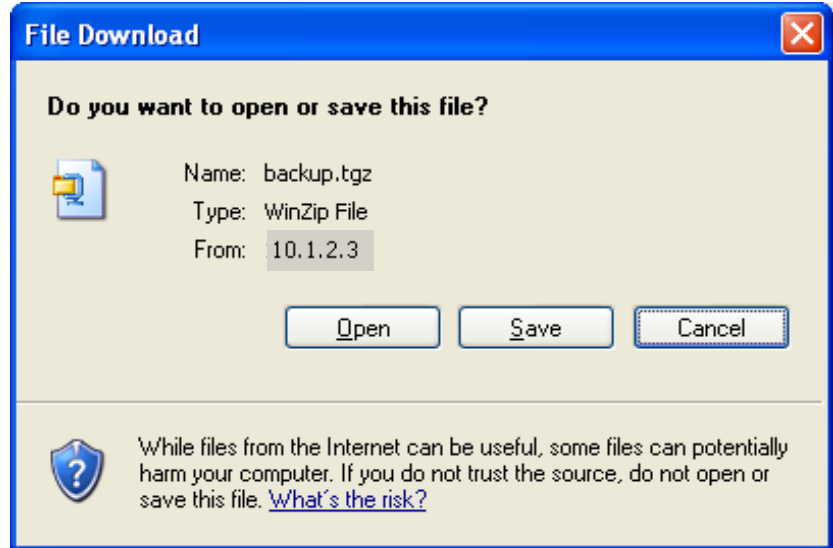

Click the **Save** button. A **Save As** dialog appears.

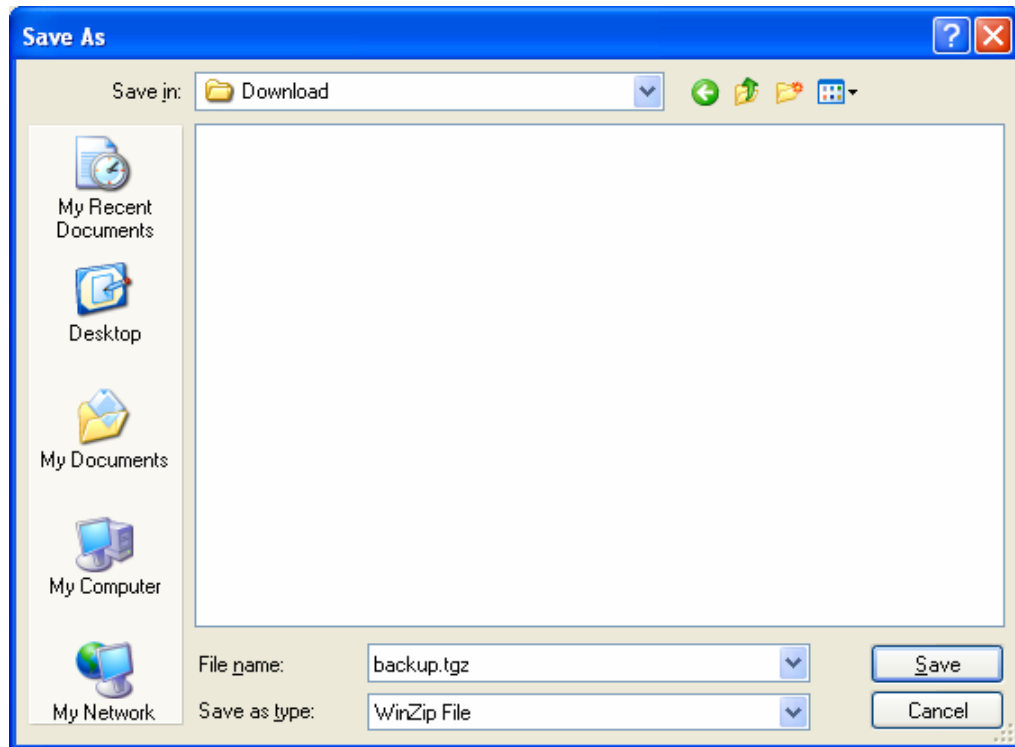

The files backed up are compressed and put into a single file, and are given the default name and file extension **backup.tgz**. Following normal Windows® conventions, the backup file may be renamed and given any extension, and saved in any folder desired. To save the backup file with an extension other than .tgz, open the **Save as type** combo box and select **All Files**.

Restoring Backed-Up Files

To restore the controller's backed up system files, click the **Restore files from backup** link. The web page shown below appears.

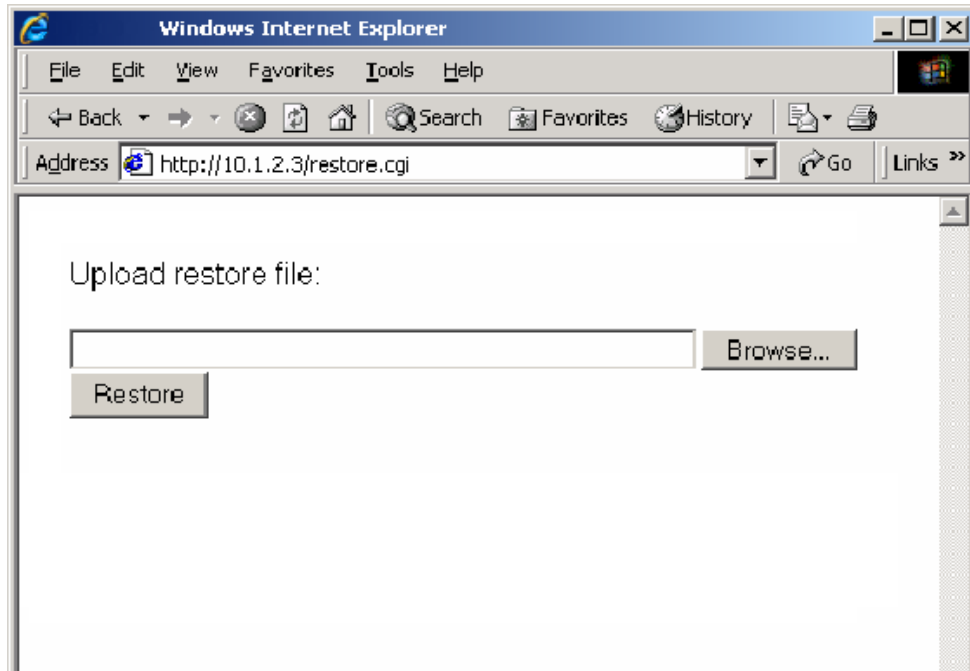

Click the **Browse...** button to locate and select the backup file to be sent to the controller.

Click the **Restore** button to send the file to the controller. If the file transfer is successful, the web page shown below will be displayed.

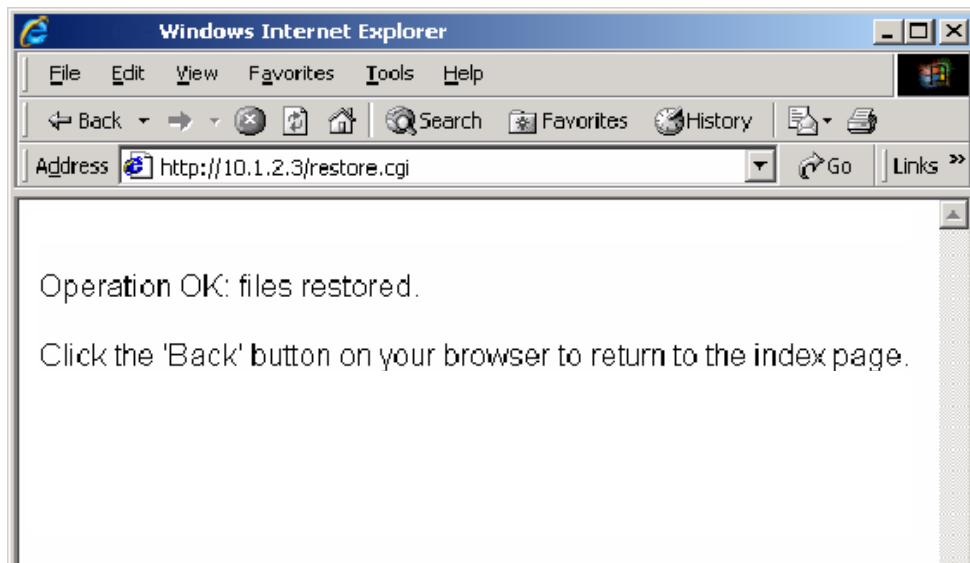

From a Controller

Backup

1. Insert a USB jump drive into the USB port on the controller.
2. From the home screen touch **Apps Button** then **Utilities**.
3. From the **Utilities** screen select **Backup**.
4. Enter a file name at the **Backup** dialog popup ("Backup" is the default name) and press **Save**.
5. From the **System Utilities** screen select **Safely remove USB memory**.

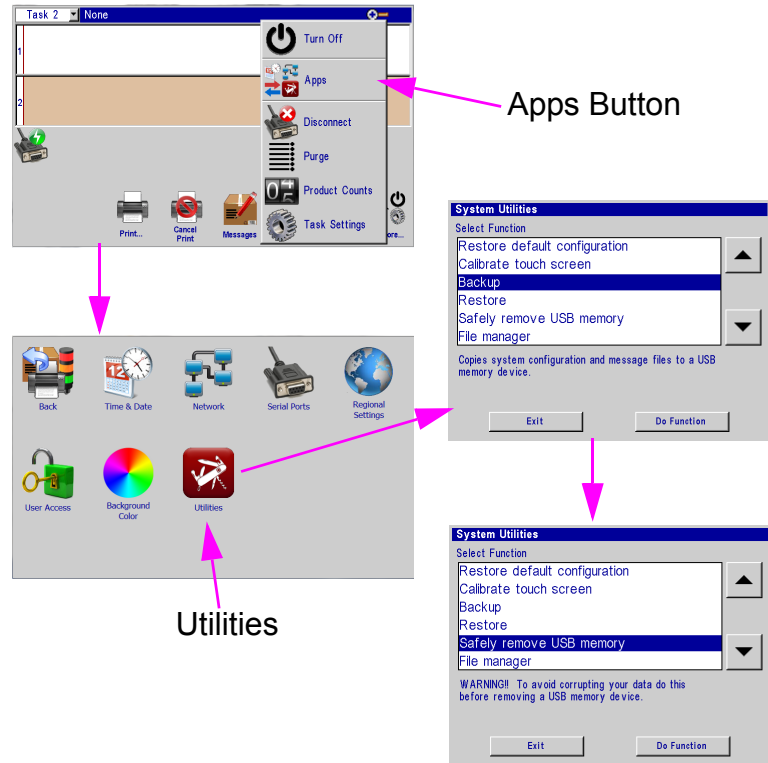

Restore

6. Insert a USB jump drive into the USB port on the controller.
7. From the home screen touch **Apps Button** then **Utilities**.
8. From the **Utilities** screen select **Restore**.
9. Select the appropriate backup file from the **Restore** dialog popup and press **Open**.
10. From the **System Utilities** screen select **Safely remove USB memory**.
11. Restart controller for new settings/backup to take effect.

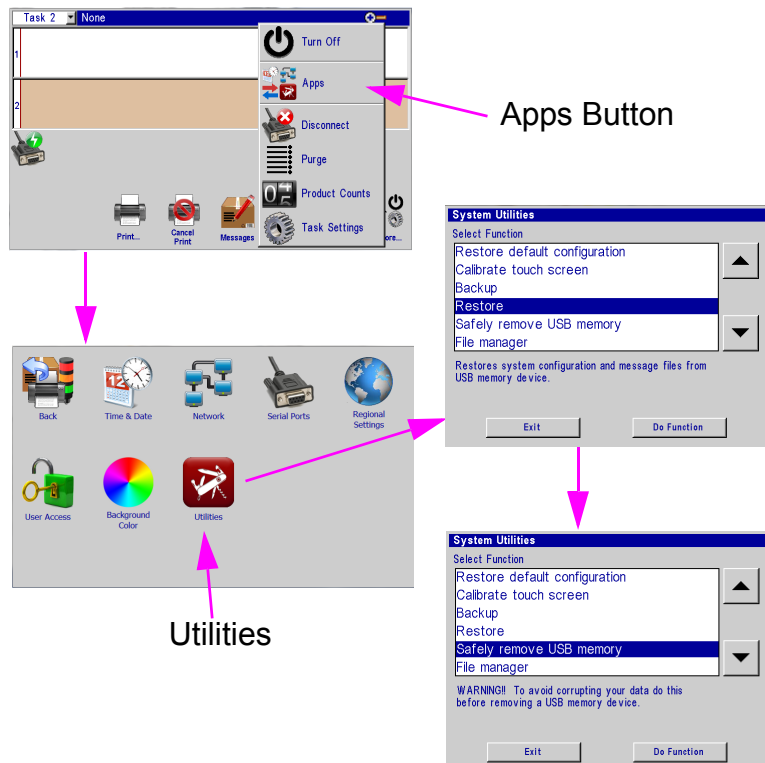

Appendix D: Configuring a PC to Communicate with the Handheld

This appendix has instructions for setting the IP address and subnet mask of the PC so it can communicate with the Handheld Controller. Included are instructions for Windows XP® and Windows 7®.

Windows XP®

1. Open the **Start** menu; select **Settings**, then **Network Connections**.

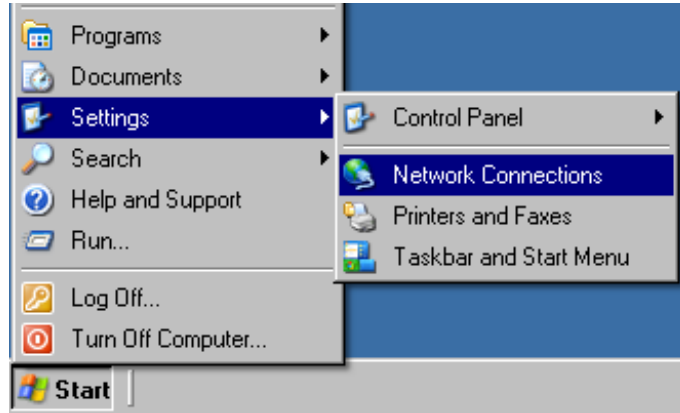

2. Click **Local Area Connection**, then open the **File** menu and select **Properties**.

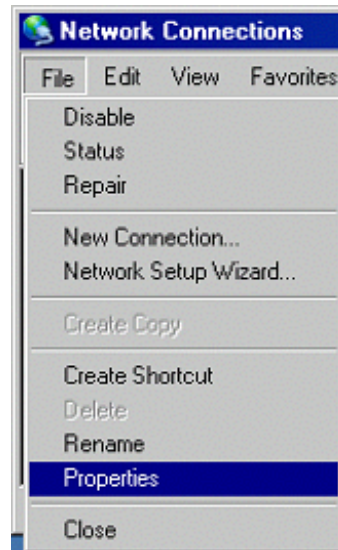
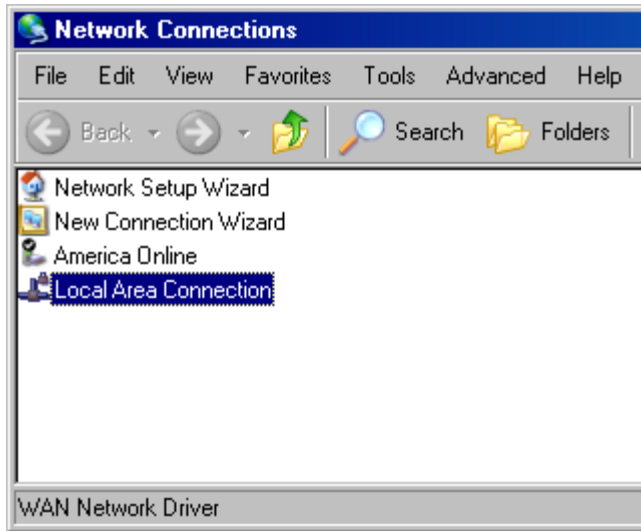

- 3. Select **Internet Protocol (TCP/IP)** then click the **Properties** button.

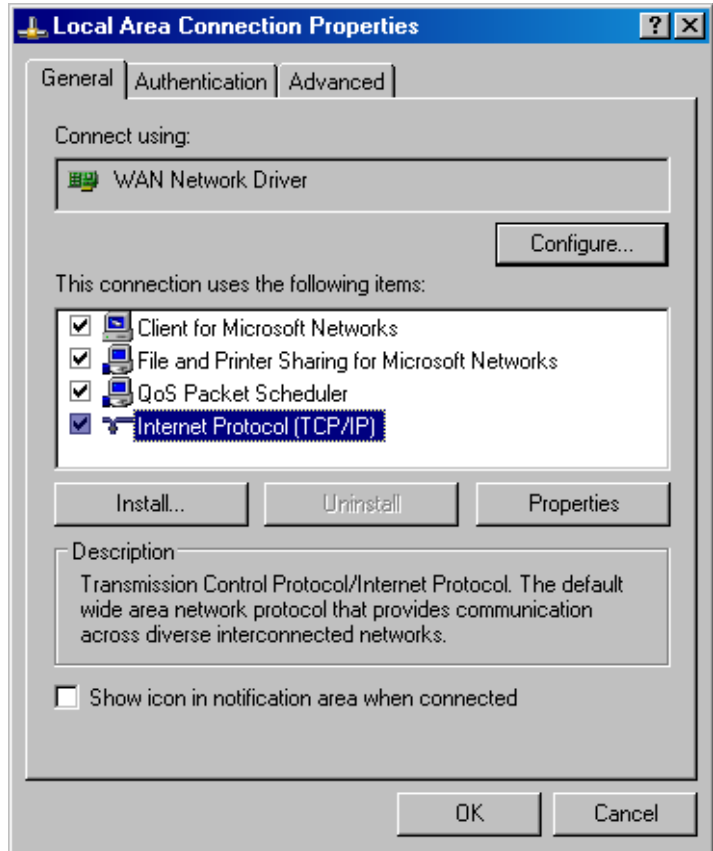

- 4. Click the **Use the following IP address** radio button. Enter an IP address of **10.1.2.4**, a subnet mask of **255.255.255.0**, and click the **OK** button.

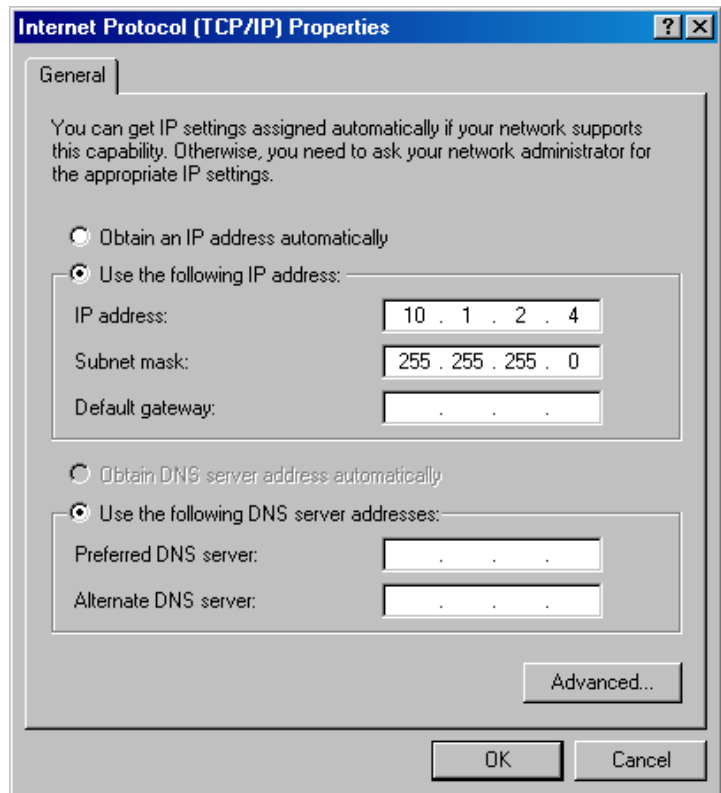

Windows 7®

1. Open the Start menu; select Control Panel; then Network and Sharing Center.

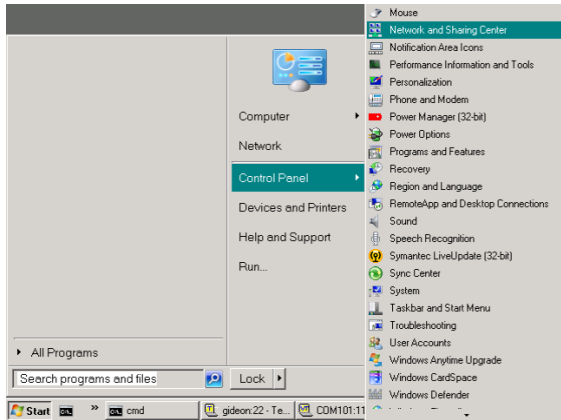

2. Click Local Area Connection, then click Properties button.

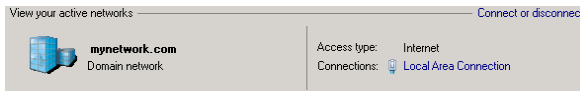

3. Select Internet Protocol Version 4 (TCP/IPv4). Then click the Properties button.

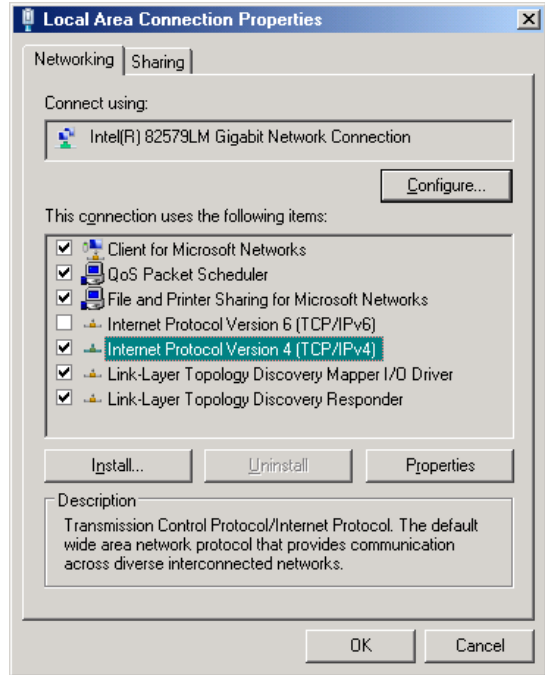

4. Click Use the following IP address radio button. Enter and IP address of 10.1.2.4, a subnet mask of 255.255.255.0, and click the OK button.

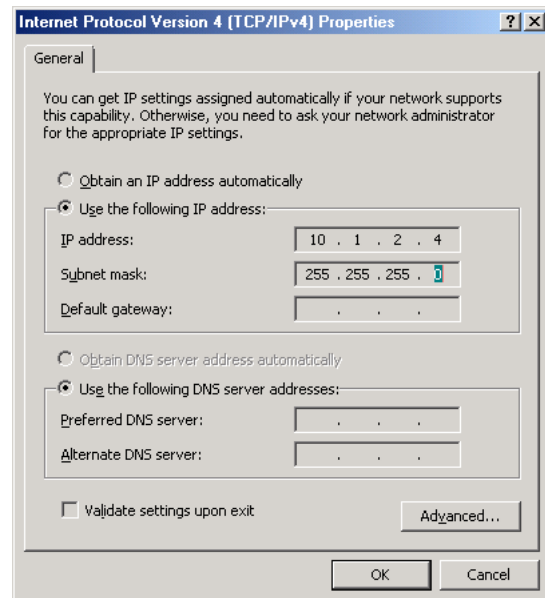
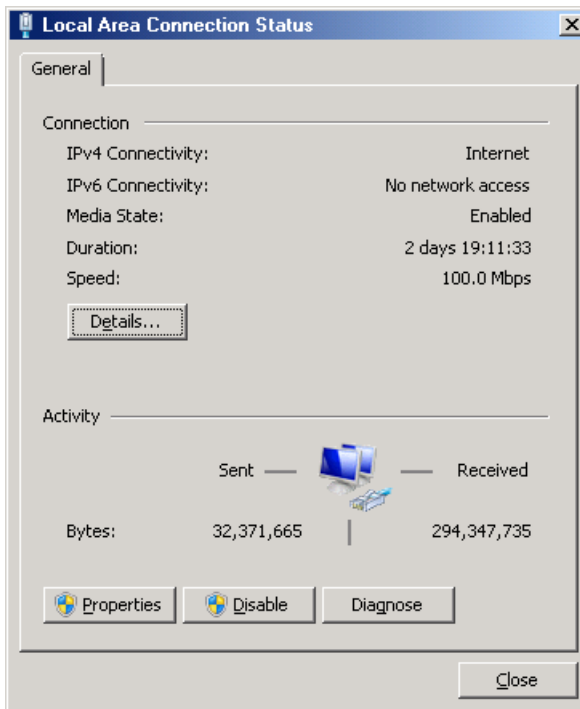

Appendix E: Font Samples

Arial 30 - 1/10 in (2.54 mm):

AaBbCcDdEeFf
1234567890

Arial 75 - 1/4 in (6.35 mm):

AaBbCcDdEeFf
1234567890

Arial 150 - 1/2 in (12.7 mm):

AaBbCcDdEeFf
1234567890



For best results printing the next two fonts use an external encoder. The top images were printed with an external encoder. The lower images were printed using the "Auto Speed Detect" mode (without external encoder) from the controller or InkJet Demo software.

Arial 225 - 3/4 in (19.05 mm):

AaBbCcDdEe
AaBbCcDdEe

Arial 300 - 1 in (25.4 mm):

AaBbCcDd
AaBbCcDd

Appendix F: Creating Logo Files

Open **Paint** from a PC by selecting **Start, All Programs, Accessories,** and then **Paint.**

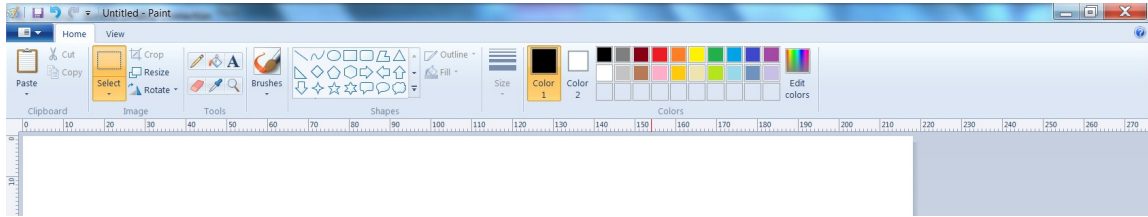

Navigate to the **Image Properties** dialog box via the drop down menu.

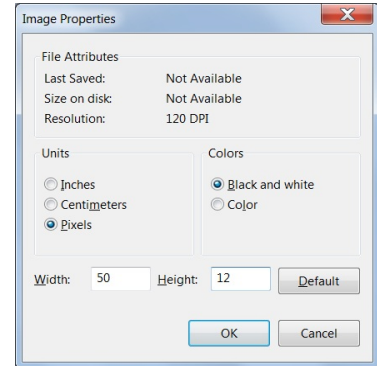

Thermal Jet: Enter the Width and Height of the logo in Pixels. For practical purposes the maximum height of a logo is 150 pixels if the logo is printed with a 1/2" print head, and 300 pixels if printed with a 1" print head. The absolute maximum logo height is 1200 pixels, but logos that cross print head boundaries will likely exhibit registration problems when printed. Maximum logo width is 32,767 pixels, or print columns (109.22 in / 2,774 mm when printed at 300 dpi.)

Select **Black and white** for the Colors.

Draw the pixels of the logo using the drawing tools. See the example below.

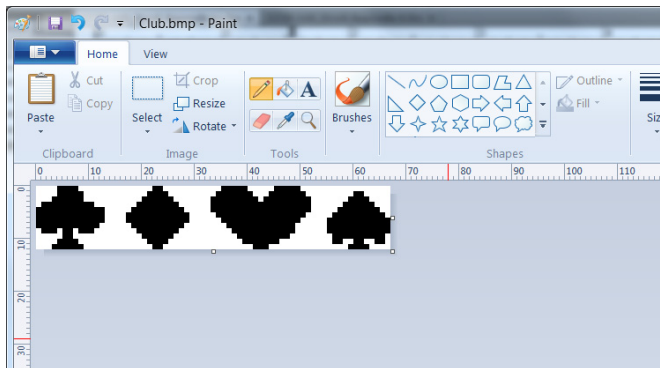

Next, click the **Rotate** button; **Rotate Left 90° (CCW 90°).**

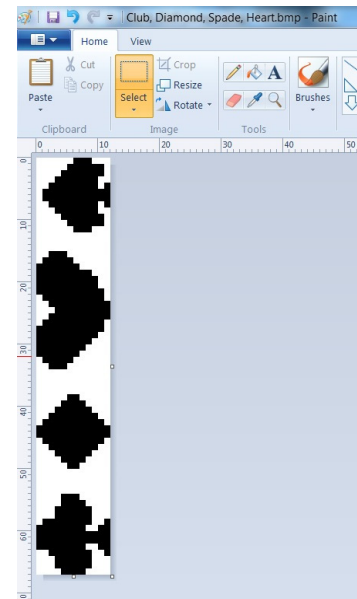

From the **File Menu**, select **Save As** and save the logo with a convenient name and directory location.



NOTE: If this logo is imported from another document or software, make sure that the first step taken is to **Save As a Monochrome Bitmap (bmp)**, and then **Resize** to the appropriate height.

Appendix G: Controller and Print Head File Management

File Manager



NOTE: A .bmp (logo) or .fnt (font) file must reside on both the controller and print head(s) to be correctly selected, displayed, and printed. Ensure the file names are less than 15 characters long.

1. If logo or font files are to be transferred, place them on a portable USB storage device in a convenient location and insert it into the controller USB port.
2. Touch the **Apps** button on the **Home** screen menu, and then select the **Utilities** button.

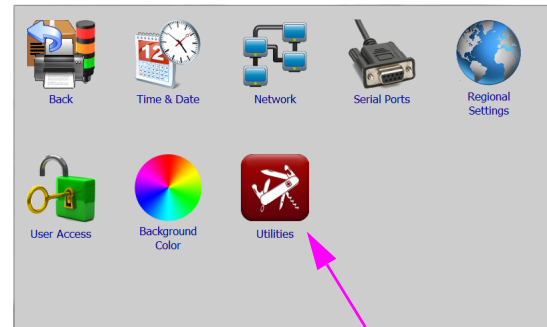
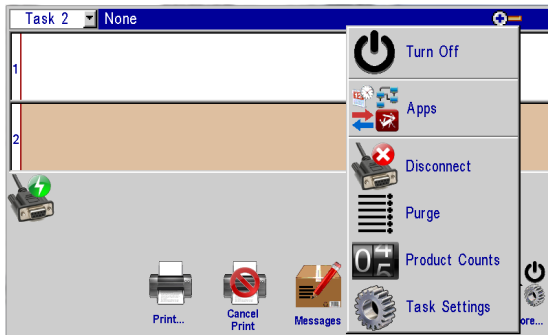

Utilities Button

3. Scroll to the bottom of the **Select Function** list and select **File manager**. Press the **Do Function** button; the **File manager** screen is displayed.

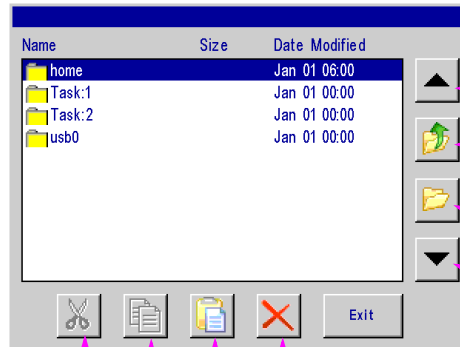
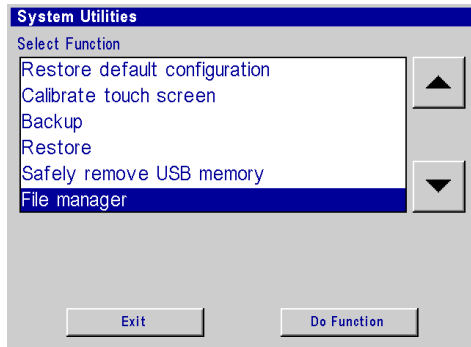

- Scroll Up
- Close Folder, Go Up One Level
- Open Folder
- Scroll down

- Cut
- Copy
- Paste
- Delete

The **home** folder contains all folders and files related to controller operation.

The **Task:1** and / or **Task:2** folders contain all font and logo files resident on the print head(s) in that daisy chain.

The **usb0** folder contains all folders and files resident on the USB storage device.



NOTE: Cut, Copy, Paste, and Delete function the same way as any software. Navigate to any file in any of the folders and perform the desired function. In addition, however, files are not allowed to be copied from any task (the print heads).

Transferring Logo and Font Files



NOTE: Files cannot be transferred to the print head while printing. Pause print first.

On the controller, logos are stored in the `/home/bmps` folder, and fonts are stored in the `/home/fnts` folder. Files are automatically placed in the correct folders when transferred to the controller from a PC using a web browser; they must be manually placed in the correct folder when being transferred from a USB drive using the copy-and-paste method.

Uploading a file to a print head loads the file on all print heads on the task. A step-by-step example of uploading a logo file to task 1 print heads follows.

1. As shown in the "File Manager" section, make sure USB storage device is installed and the **File manager** selection screen is present on the controller.
2. Select the **usb0** folder and press the **Open Folder** button.
3. Navigate to a previously saved file, highlight the file and press the **Copy** button. The file is now stored in temporary memory. In this example, a logo file will be transferred.
4. Press the **Close Folder** button, then the **Go Up One Level** button until the **File manager** selection screen is present.
5. Select the **home** folder, press the **Open Folder** button, and select the **bmps** folder. Store logos in the **bmps** folder:

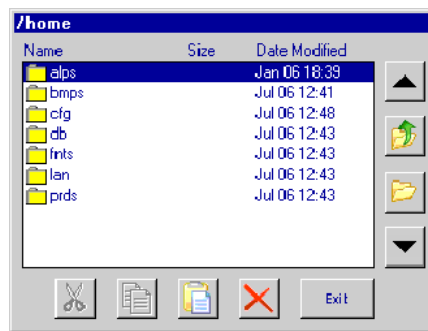
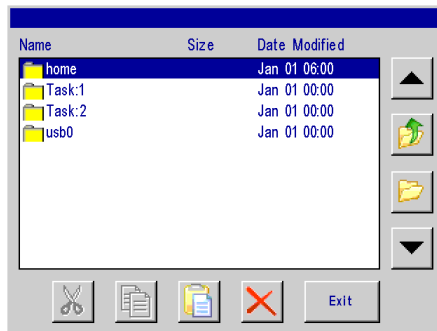

6. The display shows a list of available files. Select and open the **bmps** folder:

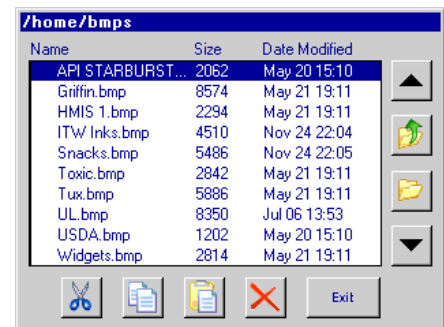

7. Select the file to be uploaded to the print head(s) and then touch the **Copy** button.
8. Close the **bmps** folder, returning to the **home** folder level.
9. Close the **bmps** folder, returning to the top level.

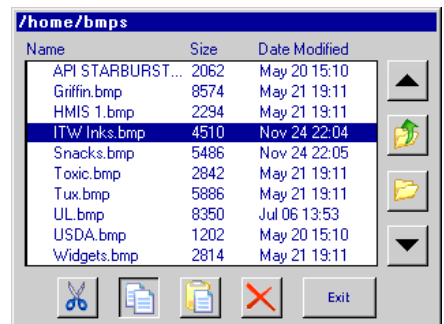

10. Select and open the **Task:1** folder. The display shows a list of all files on print head #1 only; it is assumed that all print heads have the same files.
11. Touch the **Paste** button. The file is uploaded to all print heads on the task, after which the file list is updated, showing the newly added file.

While the file is uploading, an hourglass is displayed, and the red LED on the back of each of the print heads on the task's daisy chain blinks.

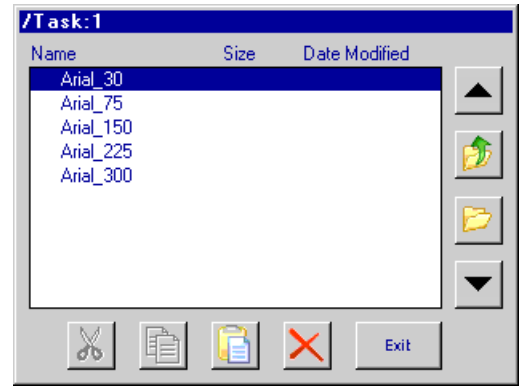

Removing a File

To remove a file from all print heads on a task:

1. Select and open the **Task:1** folder.
2. Select the file to be deleted, then touch the **Delete** button.

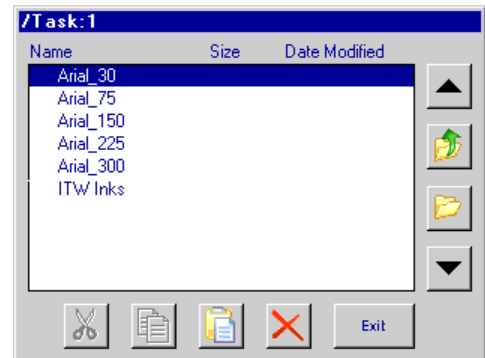

2. Select the file to be deleted, then touch the **Delete** button.
3. The file is deleted and the file list updated.

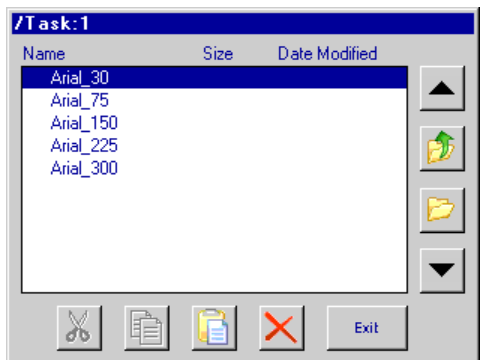
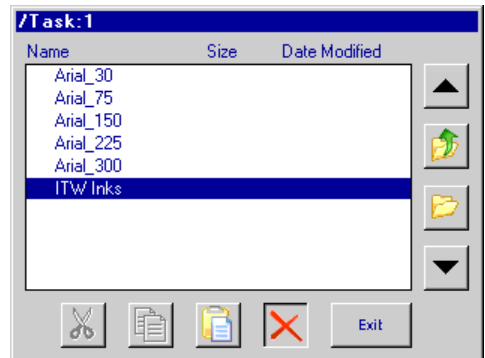

Appendix H: Communicating Directly to the Print Head

The 1/2" (12.7 mm) and 1" (25.4 mm) print heads can be controlled by direct serial communication. Refer to the serial protocol document 5780-316N when communicating directly to the print head without the use of a controller or the InkJet Demo software interface.

Appendix I: Aligning the 1" (25.4 mm) Print Head



NOTE: This procedure assumes that the user has already installed the equipment per the installation procedure. (See "Section 2: Quick Start" on page 2.) In addition, an encoder should be used for the best horizontal alignment between both print cartridges.

4. Ensure the front face of the print head is perpendicular to the substrate being printed.
5. Create a message using the Arial 300 font and run a print sample with the actual product.
6. Observe the vertical overlap or gap between the two cartridges. If there is significant overlap, loosen the mounting screws and rotate the print head bracketry counter-clockwise. If there is a gap between the halves, rotate the bracketry clockwise.
7. Snug the mounting screws and run another print sample. If the overlap or gap is not acceptable, then repeat the previous step.
8. Repeat the previous two steps until the two cartridges are matched vertically.
9. Fully tighten the mounting hardware.
10. Now observe the horizontal alignment of the characters.

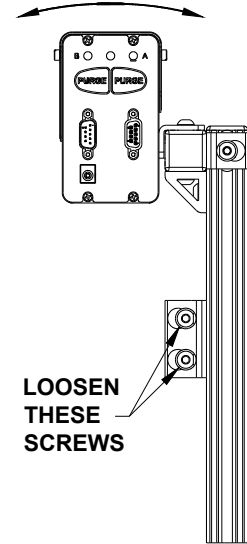

11. Horizontal misalignment can be compensated electronically through the controller or InkJet Demo software program by navigating to **Task Settings** (System Setup Screen) and then touching the print head in question.
12. An adjustment box, labeled as **A to B offset adjustment**, is available to compensate for any horizontal misalignment. Increase or decrease the number in the box and press **Apply**. Valid settings are 310 to 350. The next print will have adjusted the alignment one way or the other. Repeat this step until the desired horizontal alignment is achieved.

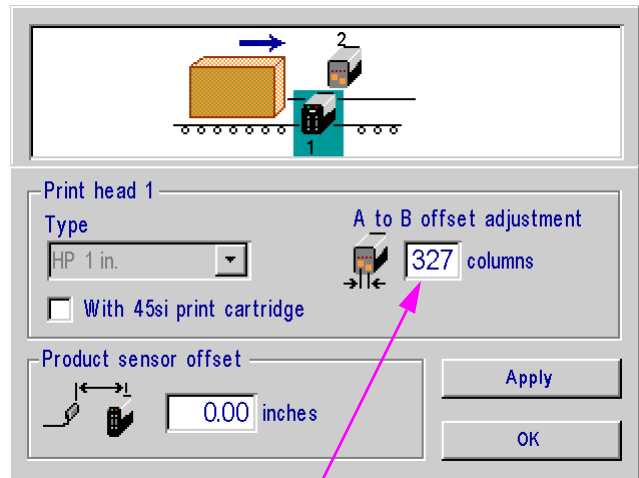

Press on this box to highlight, and then enter an adjustment value

Appendix J: Bulk Ink Supply



Wear safety goggles when working with industrial inks and solutions!



WARNING: Disconnect power during installation.



CAUTION: Sudden impact to the installed print head (caused by moving the conveyor with the print system attached or moving the print system from one location to another) can cause ink to seep out the front of the print cartridge. To keep this from happening disconnect septum fitting, remove print cartridge, and depressurize the bulk ink supply before moving the print system.



CAUTION: Failure to properly bleed the air from the ink lines before connecting the septum fitting to the print cartridge could damage the print cartridge.

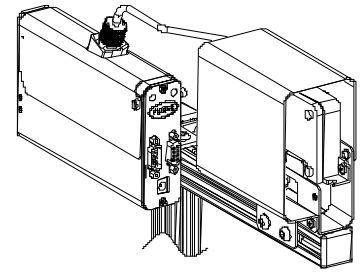

System Components

- Print Head
- Regulator
- Bulk Ink Supply
- Controller or PC (Handheld controller requires the optional Hub (below))
- Beacon (optional)
- Hub (optional)

Installation

1. Mount the print head(s), bulk ink supply, and controller (if applicable). Note: The bulk ink supply can be a maximum of three feet above or below the print head(s). The regulator must be mounted on the same horizontal bar as the print head. See page 64 for print down application.

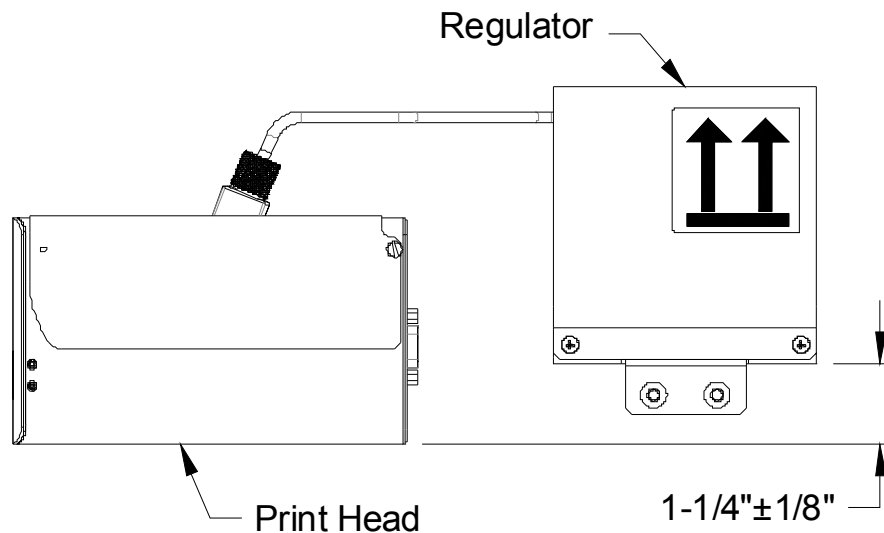

For the system to function properly it is critical that the regulator be positioned appropriately in relation to the print head as shown.

2. Make ink line connections from the bulk ink supply to the regulator per the diagram below; the trunk line should be made as short as practical. (CAUTION: Do not connect septum fitting to the print cartridge at this time.)

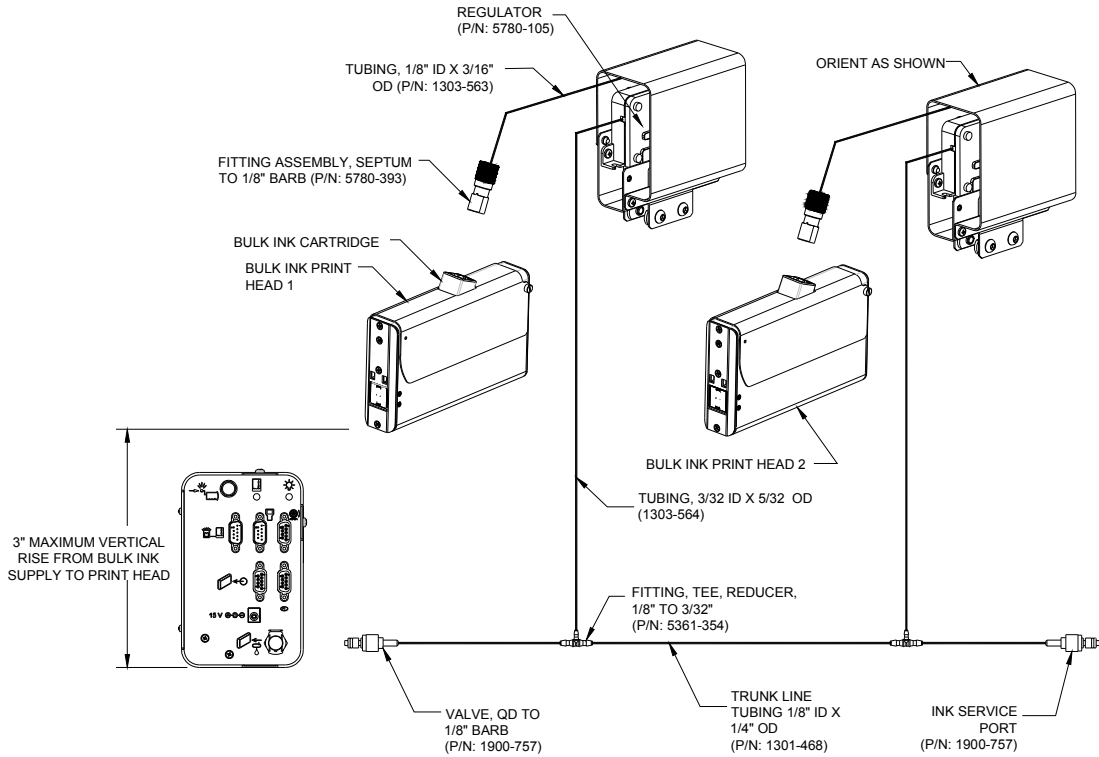

3. Make all electrical connections as shown, including all power connections per the diagram below.

BULK INK CONNECTIVITY

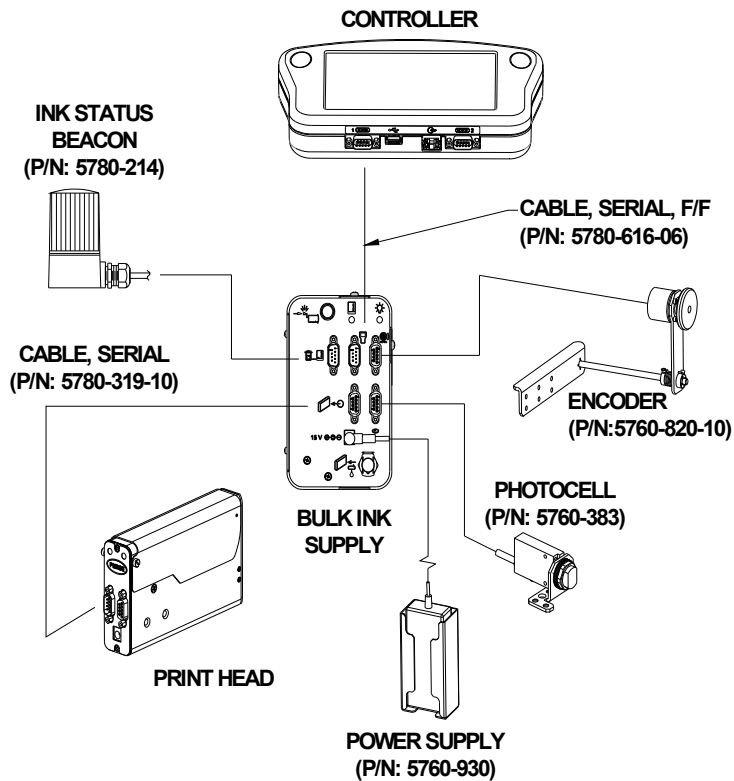

4. Insert print cartridges into the print heads and a 350 ml ink cartridge in the bulk ink supply.
5. Bleeding air out of the ink lines:

a) At the ink service port of the trunk line, depress the valve of the fitting in short spurts into a rag or trash can. Continue this until all air has been bled out of the main trunk line.

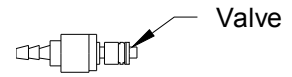

b) Connect the syringe (2466-166, supplied with the bulk ink system) to the septum fitting. While holding the syringe and tubing above the regulator, slowly draw the air out of the ink line. Once all of the air is out of the ink line and a small amount of ink is drawn into the syringe, disconnect the syringe and plug the septum fitting into the print cartridge. Repeat for each regulator.

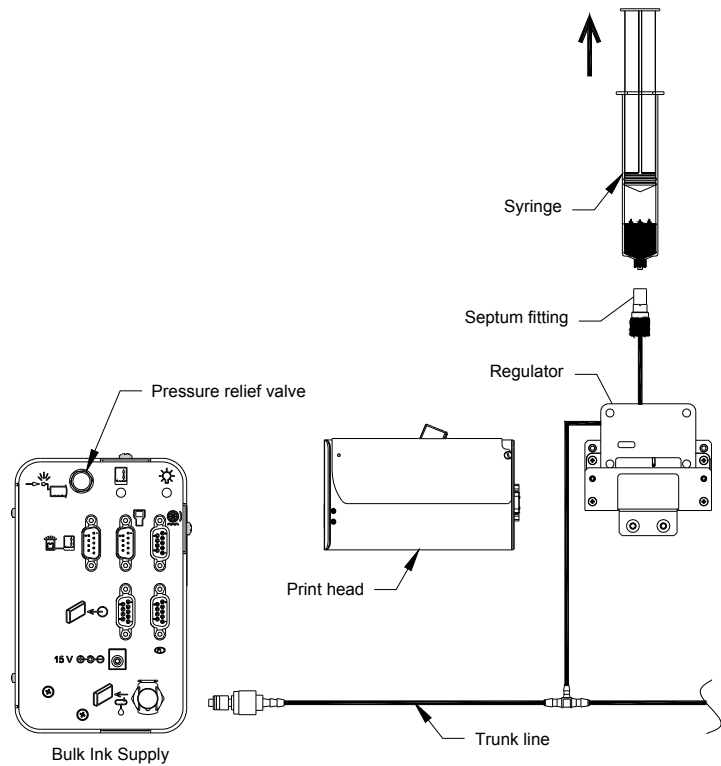

Configuring system for bulk ink supply

At the controller (or PC software) on the **Task Settings** (System Setup) screen, select the **Task Options** tab, and then select the **Uses bulk ink supply** check box.

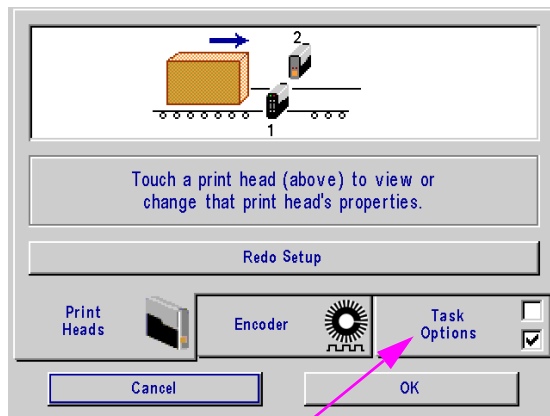

Task Options tab

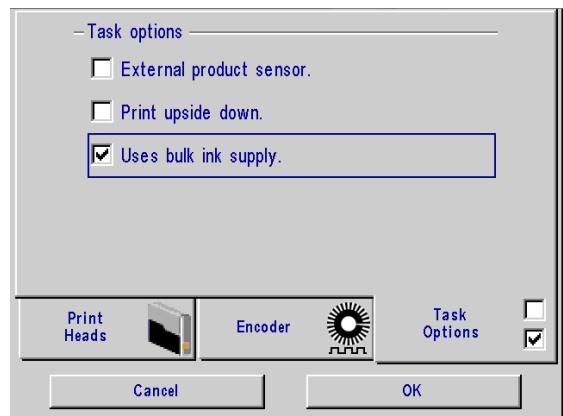

Setup for print down application

The bracketry that comes standard with the print head does not accommodate a print down setup. A separate bracket kit (5780-227) is available to allow for a print down setup. This kit includes tubing and fittings for extending the tubing between the regulator and print head. If only the tubing and fittings are needed then tubing kit 5780-211 can be used. This kit includes enough tubing and fittings to accommodate five half inch print heads or two one inch print heads.

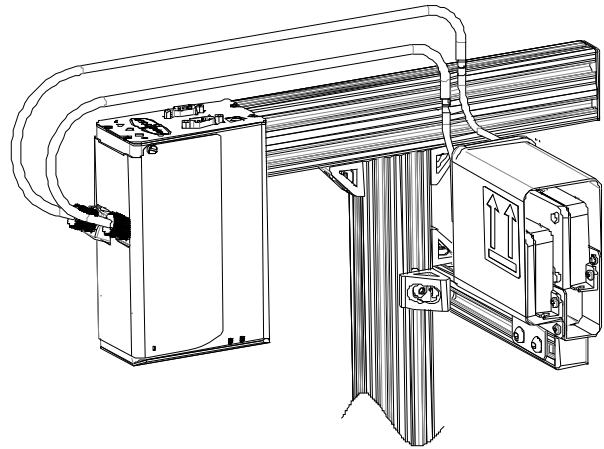

1. Mount the print head and regulator. The regulator must be positioned appropriately in relation to the print head (see figure). If the regulator is positioned too high with respect to the print head then ink may seep out of the print head. If this occurs simply lower the regulator until it is positioned properly.

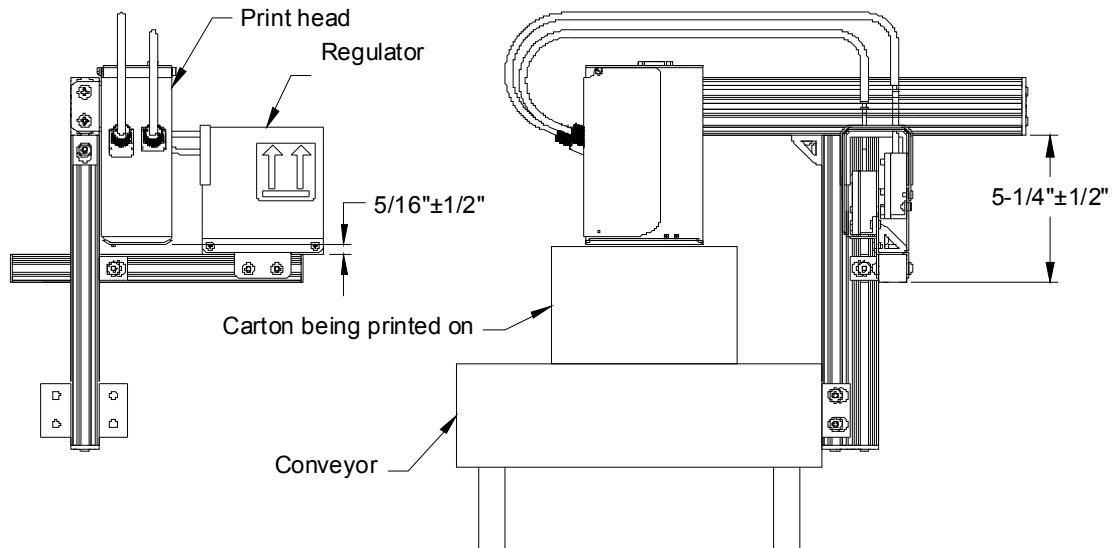

2. It will be necessary to splice in a length of tubing between the regulator and print head (see image below). This should be done before bleeding air out of the ink lines.

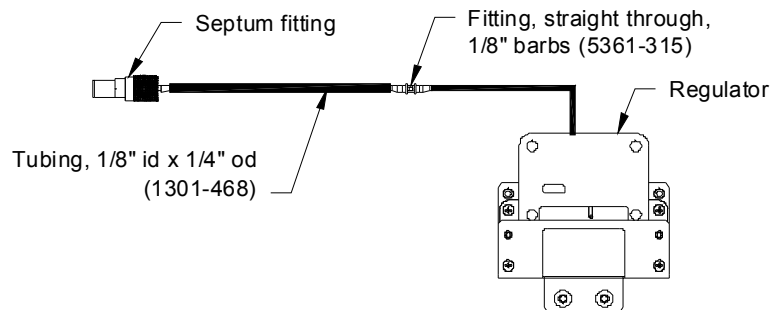

90° Tilt Setup

The bulk ink supply allows the print head to be tilted 90° from vertical versus the 45° limitation with a standard print cartridge. The relative positioning between the reservoir and print head needs to be maintained for the print head to function properly. Standard bracketry may be used to mount the print head in this orientation, however it may be necessary to extend the tubing between the reservoir and print head (reference the print down setup for instructions).

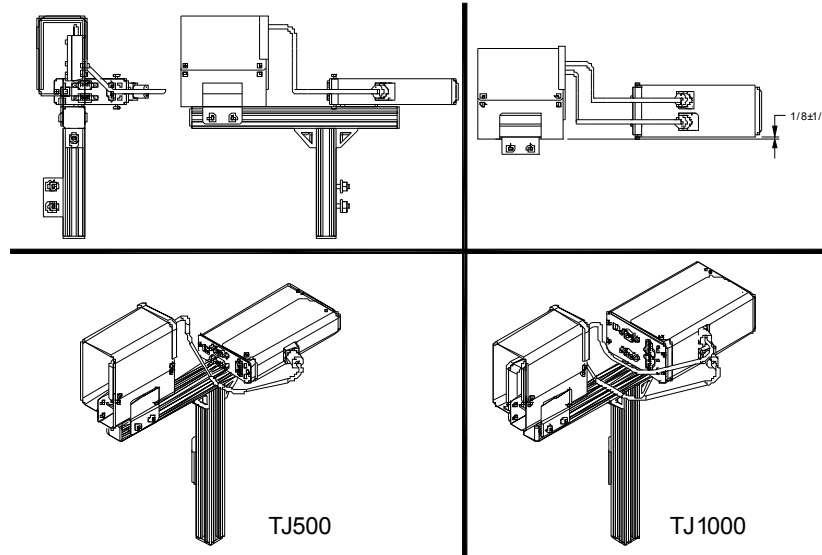

Operation

- Operating pressure of the bulk ink supply is 4-5 psi. Once pressure drops below 4 psi the air pump will turn on and pressurize the ink supply up to 5 psi.
- If the pump can not achieve 5 psi after running for 15 seconds the system goes into an "Ink Low" state (beacon will turn on solid) indicating the 350 ml ink cartridge is empty. The print heads will continue to print because there is still ink in the print head cartridges; this allows ample time to change the 350 ml ink cartridge.
- Changing the 350 ml bulk ink cartridge:
 - Press the pressure relief valve on the back of the bulk ink system to depressurize the ink cartridge.
 - Push in and up slightly on the cartridge to release it from the holster.
 - Insert the new cartridge. The system will detect the new cartridge and begin pressurizing automatically.
- Maximum print heads per ink system: four 1" print heads, eight 1/2" print heads, or any combination of the two totaling eight print cartridges.

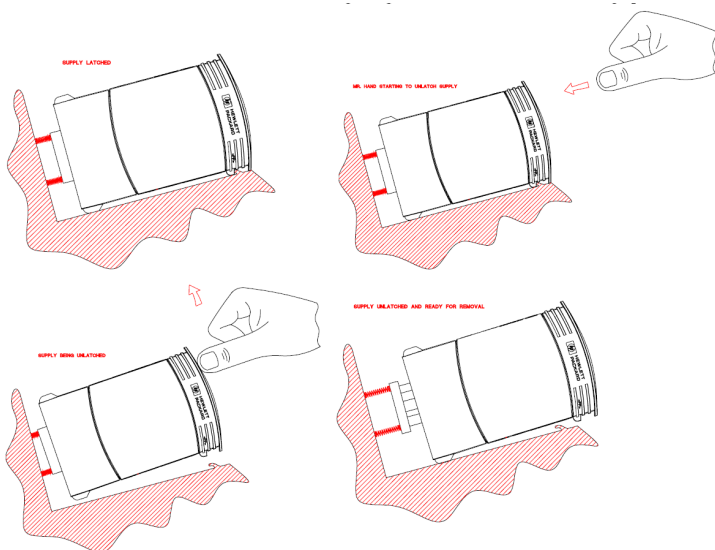

- A red LED on the rear panel of the Bulk Ink Supply, and an optional beacon, indicate the system's operational status:
 - LED/beacon is off - system is operating normally.
 - LED/beacon is on steady - normal system operating pressure (5 psi) was not achieved after 15 seconds of continuous pressure pump operation and the pump has shut down. It indicates that the ink cartridge is empty and needs to be replaced. The pump will automatically restart when the cartridge is replaced or power is cycled off and on.
 - LED/beacon is blinking rapidly - the system has experienced a rapid loss of pressure, possibly due to a break in an ink line, and has shut down.
 - The LED repeatedly blinks rapidly for one second, then goes out for one second, blinks for one second, goes out for one second, etc.; the beacon continuously blinks rapidly with one second "off" periods - indicates a missing ink cartridge or the cartridge is not being detected by the system.

Appendix K: Part Numbers - Consumables and Service Parts

Consumables



Ink Cartridge: The SoloSeries print head has been engineered and designed to work with Foxjet ink cartridges. The SoloSeries **Smart Level Ink Detection System**, which provides ink level monitoring to ensure complete ink usage and product safety, will not be functional if used with non-Foxjet ink cartridges.

Inks

Part No.	Description	Package	Shelf Life
5780-201FX	Solo 100 Porous Media, Black	5 Cartridges	1 year
5780-201FX-R	Solo 100 Porous Media, Red		
5780-202FX	Solo 200 Porous Media, Black, Extended Decap		
5780-212FX	Solo 300NP Non-Porous Media, Black		
5780-261FX	Solo 450NP Non-Porous, Black, Extended Decap		6 months
5780-235FX	Solo 200 Porous Media, Barcode, Black	One 350ml Ink Cartridge	1 year
5780-220FX	Solo 100 Porous Media, Bulk Ink, Black		
5780-219FX	Solo 100Porous Media, Bulk Ink, Black		

Service Parts

SoloSeries45

Item	Kit No.	Description
1	5760-302	Power Supply, Print Head
2	5780-002FX	SoloSeries45 Complete Print Head Kit with Mounting Bracketry, Power Supply, Data Cable, & PC Software
3	5780-203FX	Cover, Enclosure, SoloSeries45 Print Head, Standard
	5780-203BIFX	Cover, Enclosure, SoloSeries45 Print Head, Bulk Ink
4	5780-226FX	PCB Replacement Set
5	5780-205FX	Print Head Replacement, Standard
	5780-217FX	Print Head Replacement, Bulk Ink
6	5780-208	Boot, Cartridge Cap
7	5780-319-10	Cable, Print Head, 10'
8	2464-182-25	Extension Cable, Print Head, 25' (not shown)
9	2464-182-50	Extension Cable, Print Head, 50' (not shown)
10	5780-231	Regulator Replacement, Bulk Ink
11	5780-229FX	Upgrade Kit, Bulk Ink Print Head (Includes Item 3-bottom and Item 10)

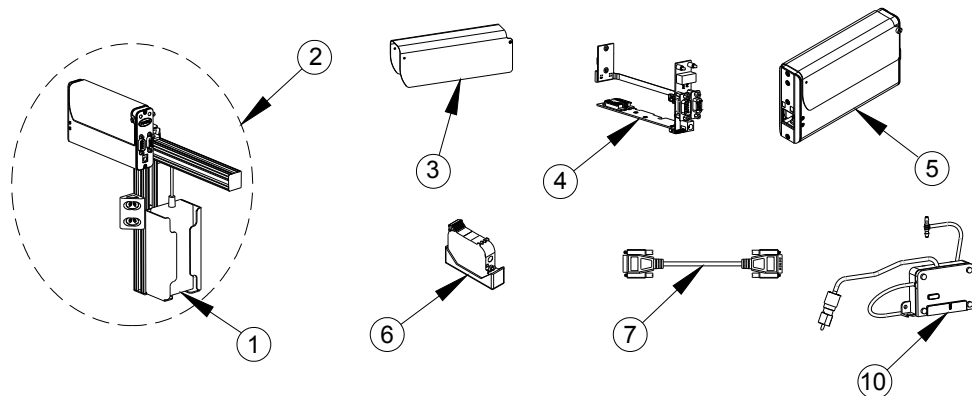

SoloSeries90

Item	Kit No.	Description
1	5760-302	Power Supply, Print Head
2	5780-007FX	SoloSeries90 Complete Print Head Kit with Mounting Bracketry, Power Supply, Data Cable, & PC Software
3	5780-225FX	Cover, Enclosure, SoloSeries90 Print Head, Standard
	5780-225BIFX	Cover, Enclosure, SoloSeries90 Print Head, Bulk Ink
4	5780-221FX	PCB Replacement Set
5	5780-215FX	Print Head Replacement, Standard
	5780-218FX	Print Head Replacement, Bulk Ink
6	5780-208	Boot, Cartridge Cap
7	5780-319-10	Cable, Print Head, 10'
8	2464-182-25	Extension Cable, Print Head, 25' (not shown)
9	2464-182-50	Extension Cable, Print Head, 50' (not shown)
10	5780-231	Regulator Replacement, Bulk Ink
11	5780-228FX	Upgrade Kit, Bulk Ink Print Head (Includes Item 3-bottom & 2 ea. Item 10)

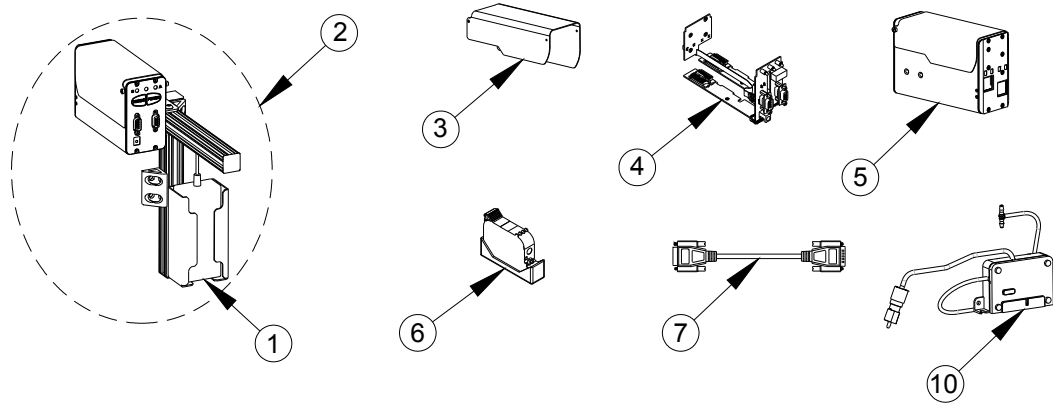

SoloSeries IS

Item	Kit No.	Description
1	5760-302	Power Supply, 15VDC, Bulk Ink Supply
2	5780-216FX	Replacement Bulk Ink Supply
3	5780-222	Internal Tubing and Fitting Replacement
4	5780-223	Vacuum Pump Replacement
5	5780-224	PCB Replacement
6	5780-209	Septum Fitting Replacement
7	5780-211	External Tubing and Fittings (not shown)

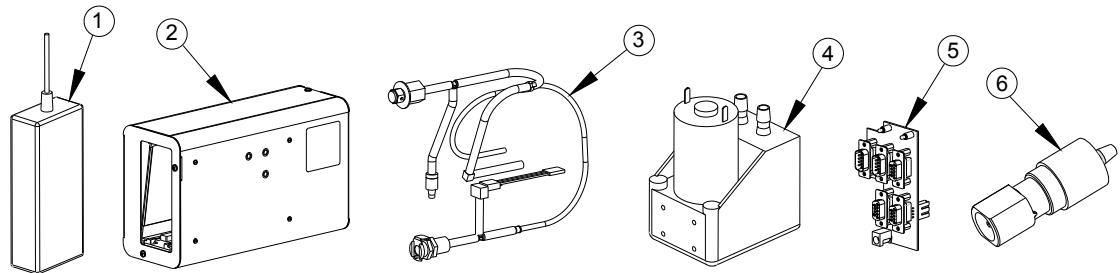

Marksman HHI Plus

Item	Kit No.	Description
1	5780-017FX	Marksman HHI Plus Controller
2	5765-227	Kit, Replacement Display, Marksman HHI Plus
3	5765-228	Kit, Replacement CPU, Marksman HHI Plus
4	5780-626	Battery (CR1220)

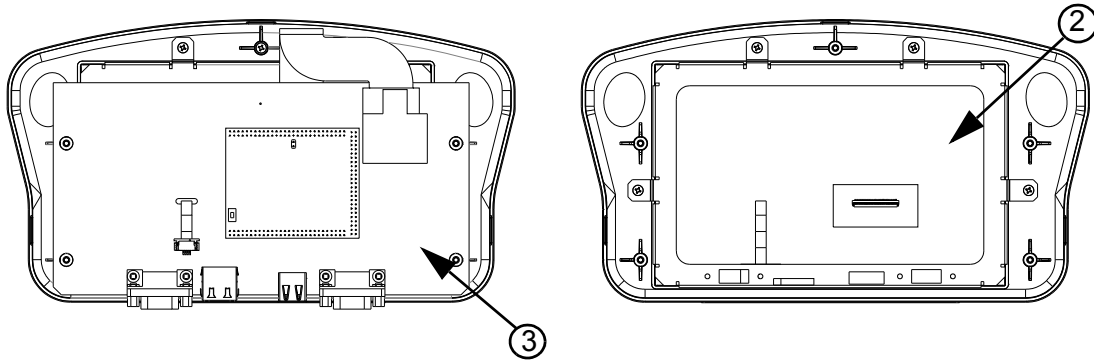

Bracketry

Item	Kit No.	Description
1	5780-234	Bracketry, Marksman HHI Mounting
2	5780-200	Bracketry, SoloSeries Print Head Mounting
3	5780-227	Bracketry, Print Down
4	5780-230	Bracket, Linear, Tool-less

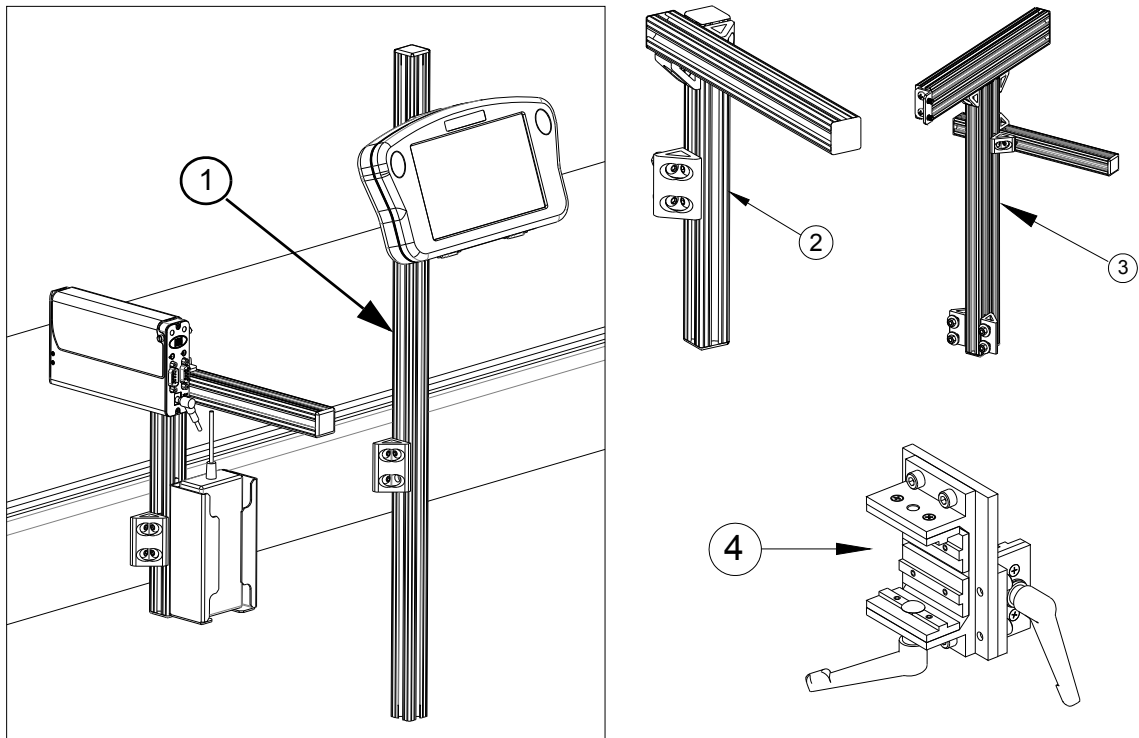

Optional Equipment

Encoder, Photocell, Accessory Hub, and Beacon

Item	Kit No.	Description
1	5760-820-IJ	Encoder Assembly with Mounting Bracket & 25' Cable
2	5765-206	Encoder O-ring Replacement
3	5760-383	Photocell
4	5780-010FX	Accessory Hub with Power Supply
5	5780-214	Beacon

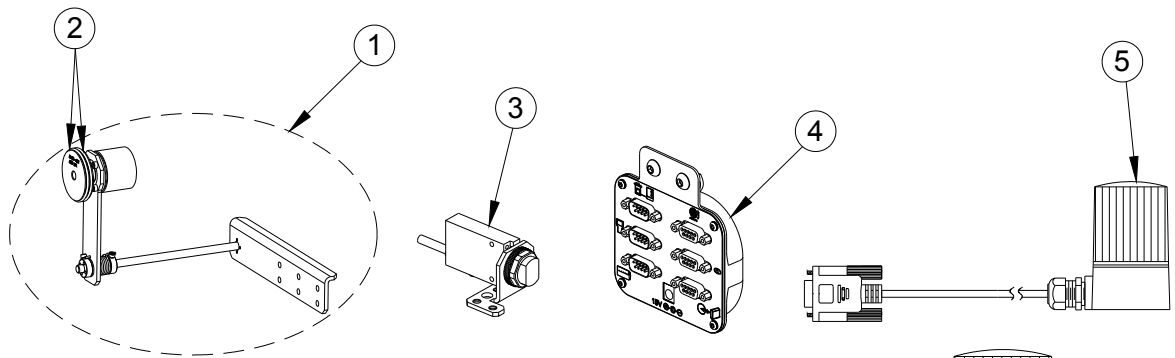

TYPICAL ENCODER MOUNTING ON OPEN AREA OF CONVEYOR BELT

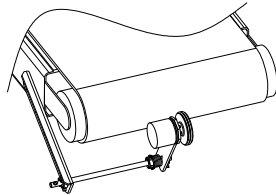

TYPICAL PHOTOCELL MOUNTING

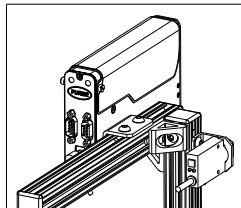

BRACKETRY MOUNTING

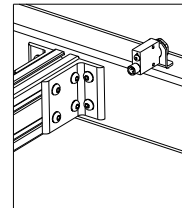

CONVEYOR MOUNTING

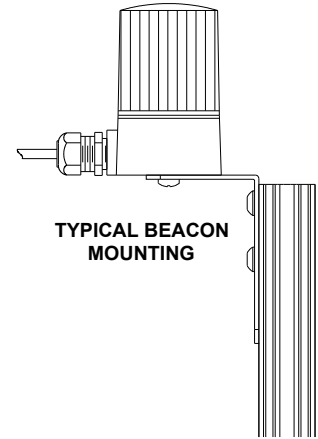

TYPICAL BEACON MOUNTING

TYPICAL ACCESSORY HUB MOUNTING

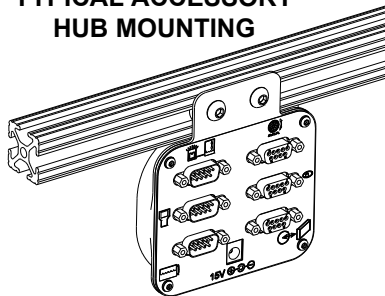

ACCESSORY HUB CONNECTIVITY

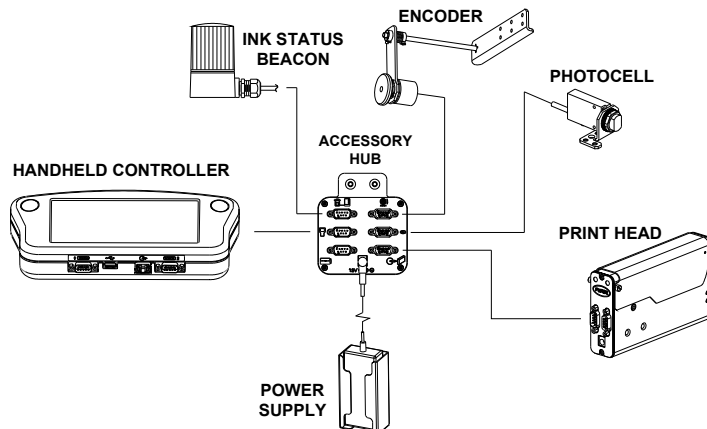

Roller & Retractor Bracketry

Item	Kit No.	Description
1	5780-206	Roller Bracket Only
2	5780-207	Roller and Retractor Bracket

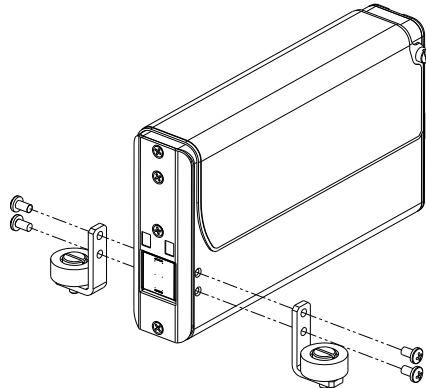

Roller Bracket Only

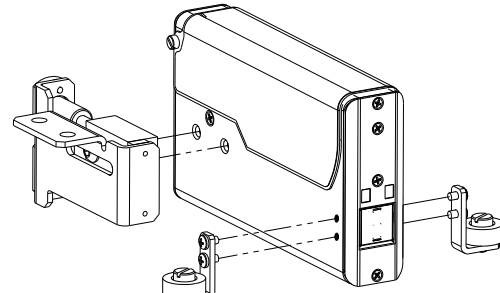

Roller & Retractor Bracketry

Maintenance

Item	Kit No.	Description
1	1901-398	Hand Cleaner, Reduran
2	5760-832	Sponge Swabs, Qty. 100
3	6600-171	Lint-free Wipe Cloths