

ITEM	PART NUMBER	DESCRIPTION	QTY
1	5760-439X04500	BAR, 3 X 3 X 45" LONG	1
2	5760-442	BRACKET, CORNER, 8 HOLE	2
3	5760-443	END CAP, 3 X 3	2
4	5241-723	SCR, M8 X 1.25 X 16mm BUT HD CAP,SS	8
5	5780-427	T-NUT, DOUBLE, M8 X 1.25	8
6	5081-743	SCR, M8 X 1.25 X 40mm SOC HD CAP,SS	8
7	5305-109	NUT, M8 X 1.25, HEX	8
8	5310-308	WASHER, 5/16 LOCK	8
9	5310-033	WASHER, 5/16 FLAT	8
10	5081-746	SCR, M6 X 1 X 12mm, SOC HD CAP, SS	4
11	2465-408	BRACKET, MOUNTING, UNIVERSAL	1
12	5241-722	SCR, M6 X 1 X 12mm BUT HD CAP, SS	8

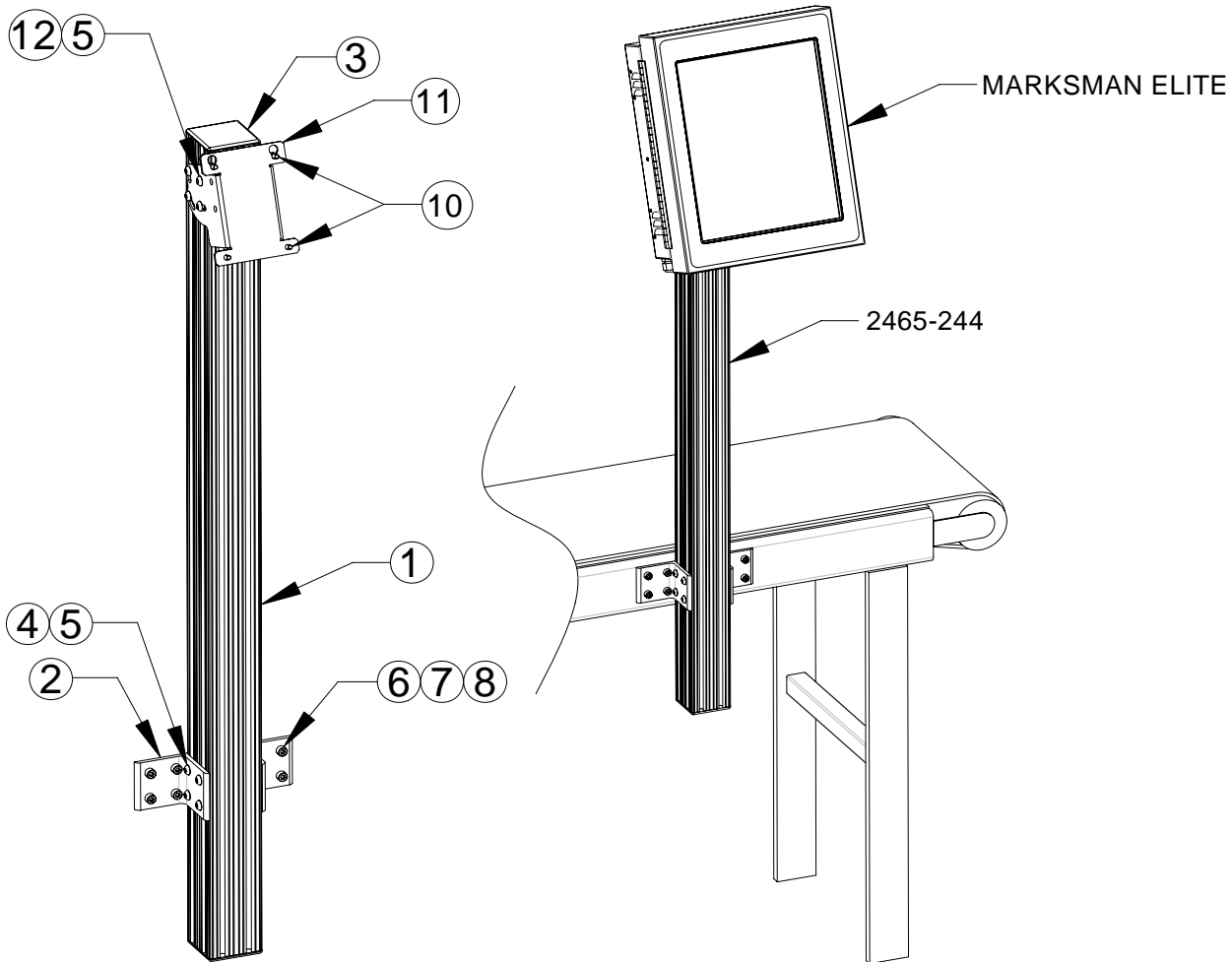

Items 6, 7, 8, and 9 are used to fasten the bracket assembly to the side of the conveyor.

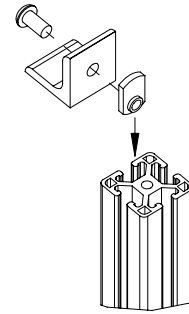