

Operations Manual

Integrated Valve Print System



5770-448
Revision A

Integrated Valve Print System Operations Manual

**5780-448
Revision A**

The information contained in this manual is correct and accurate at the time of its publication. The manufacturer reserves the right to change or alter any information or technical specifications at any time and without notice.

**©2012 Illinois Tool Works Inc.
All rights reserved
Printed in the United States of America**

Integrated Valve

Warranty:

The Valve Jet system, including all components unless otherwise specified, carries a limited warranty.

The inks and conditioners used with the Valve Jet system carry a limited warranty.

For all warranty terms and conditions, contact the manufacturer for a complete copy of the Limited Warranty Statement.

Integrated Valve

Section 1: Safety and Ink Usage	6
Section 2: Quick Start	7
Step 1: Assemble Bracketry	8
Step 2: Assemble Bracketry to Conveyor	8
Step 3: Assemble Print Head and Power Supply to Bracketry	9
Step 4: Install Pressurized Ink Can Supply and Controller	10
Step 5: Adjust Print Head to Substrate	11
Step 6: Install Tubing	12
Step 7: Electrical Connections	13
Step 8: Bleed Ink Lines and Print Heads	14
Step 9: Configure the Print Head via Controller	15
Step 10: Create a Message	16
Step 11: Print a Message	17
Section 3: Handheld Controller	18
Keypad	18
Home Screen	19
Status Screen	29
Section 4: Print Head Functionality	30
Section 5: Maintenance & Shutdowns	31
System Maintenance	31
Print Head Maintenance	31
Section 6: Troubleshooting	33
Ink Regulator Adjustment	34
Adjusting Solenoid Pre-load	34
Appendix A: Specifications	35
System	35
Typical Print Head and Bracketry	35
Print Head:	36
Handheld Controller with Valve Jet Technology:	37
Pressurized Ink Can System	38
System Interconnect Diagram	39
Appendix B: Serial Port Setup	40
Appendix C: File System Backup and Restore	41
Appendix D: Configuring a PC to Communicate with the Handheld	42
Appendix E: Creating Logo Files	43

Integrated Valve

- Appendix F: Controller and Print Head File Management 44**
 - File Manager 44
 - Transferring Logo and Font Files 45

- Appendix G: Communicating Directly to the Print Head 46**

- Appendix H: Part Numbers 47**
 - System 47
 - Consumables 47
 - Service Parts 47
 - Optional Equipment 49

Section 1: Safety and Ink Usage

Following is a list of safety symbols and their meanings, which are found throughout this manual. Pay attention to these symbols where they appear in the manual.



Wear safety goggles when performing the procedure described!



Caution or Warning! Denotes possible personal injury and/or damage to the equipment.



Caution or Warning! Denotes possible personal injury and/or equipment damage due to electrical hazard.



NOTE: (Will be followed by a brief comment or explanation.)



ESD protection should be worn when servicing internal printed circuit boards. After service to the equipment is completed, replace all protective devices such as grounding cables and covers before operating the equipment.



It is extremely important to:

- Clean up all spills with the appropriate solvents immediately and dispose of all waste according to local and state regulations.
- Wear safety glasses and protective clothing, including gloves, when handling all inks and conditioners.
- Store inks and solvents under the recommended conditions found on the MSDS (Material Safety Data Sheet).

Section 2: Quick Start

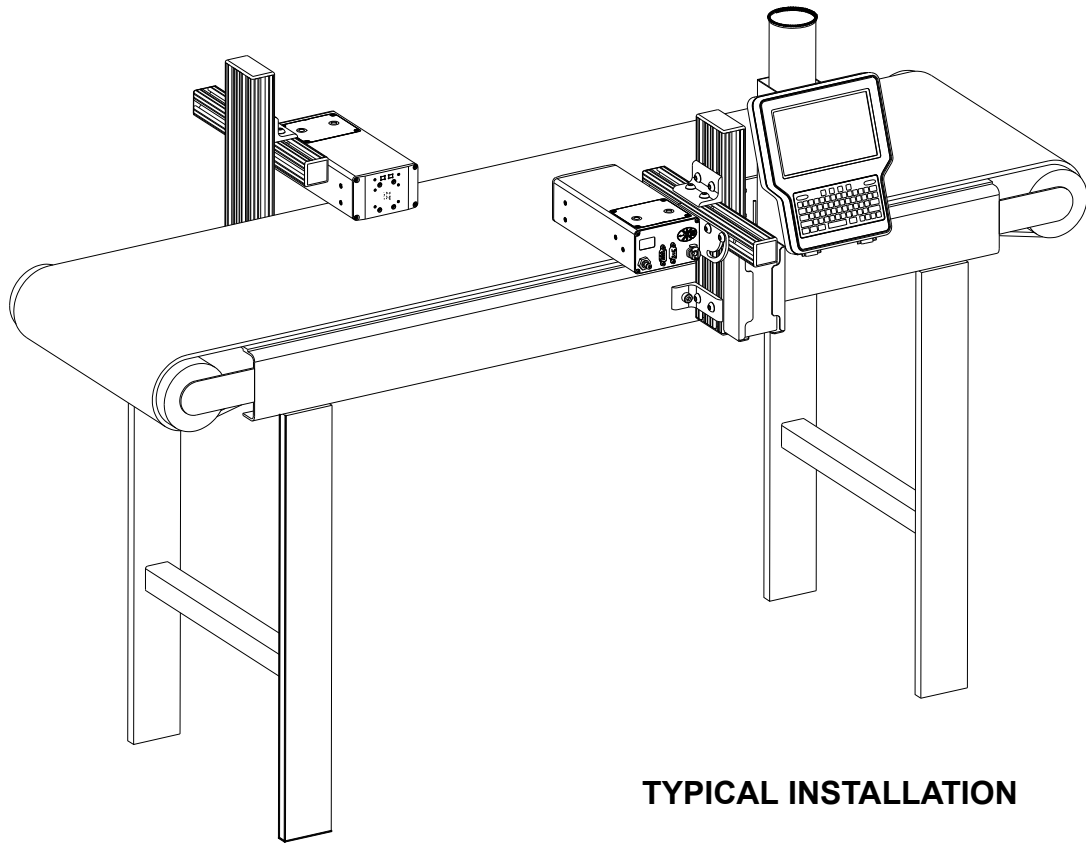

TYPICAL INSTALLATION

Contents:

- Print Head, 12 Dot Valve Jet
- Handheld Controller
- Pressurized Ink Can Delivery System
- Bracketry Kit
- Power Supply, 15 V
- Power Supply Bracket
- Power Cord
- Serial Cable
- Tubing
- Software

* Ink not included

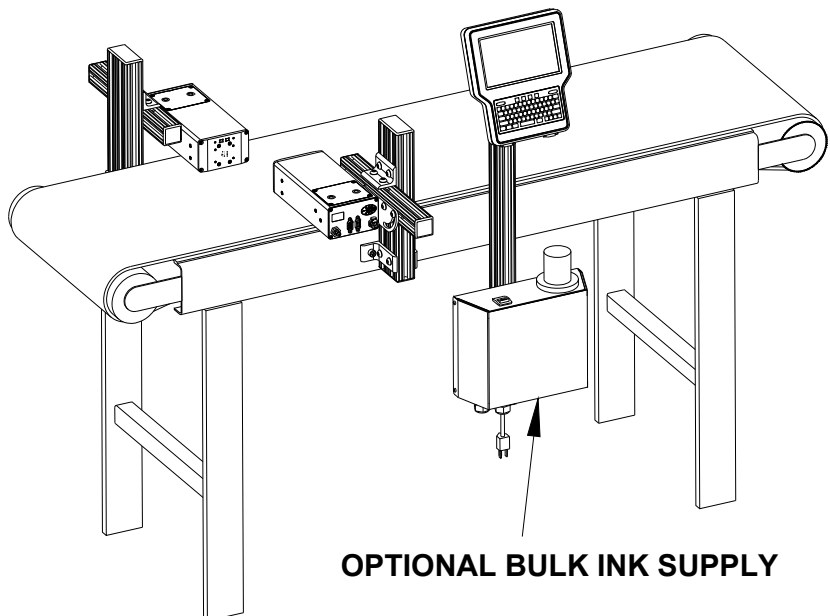

OPTIONAL BULK INK SUPPLY

Step 1: Assemble Bracketry

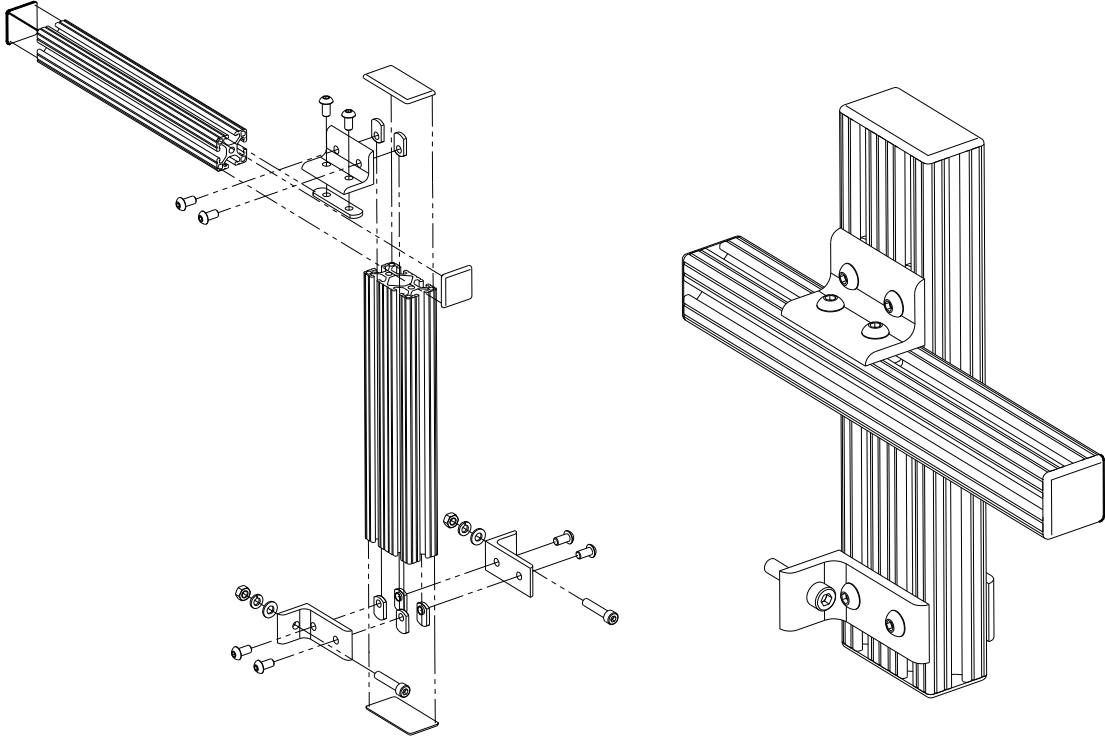

Step 2: Assemble Bracketry to Conveyor

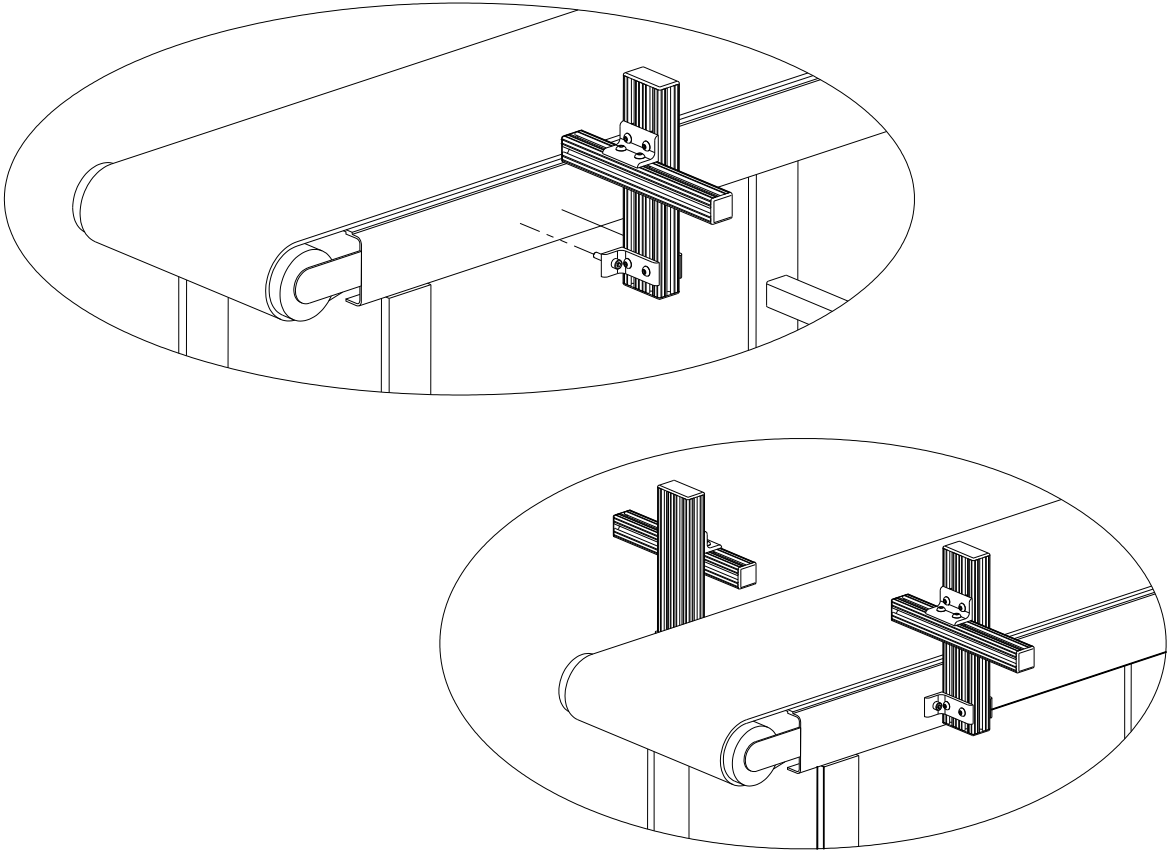

Step 3: Assemble Print Head and Power Supply to Bracketry

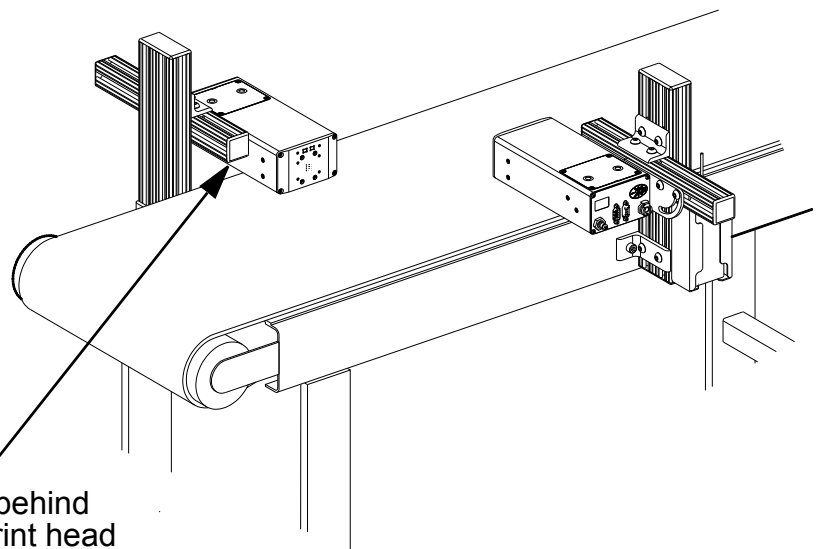
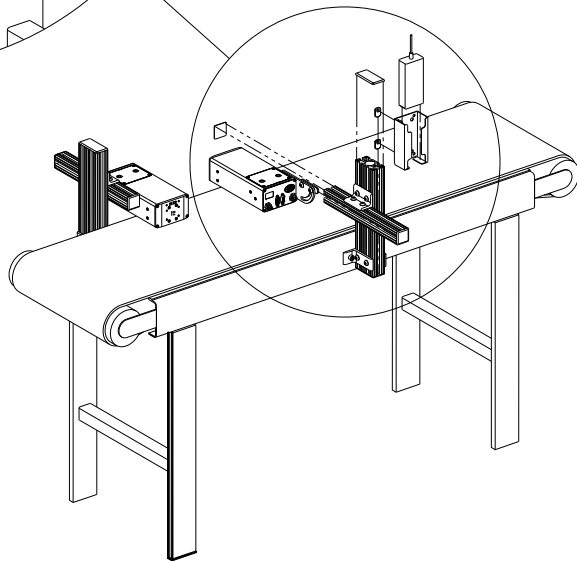
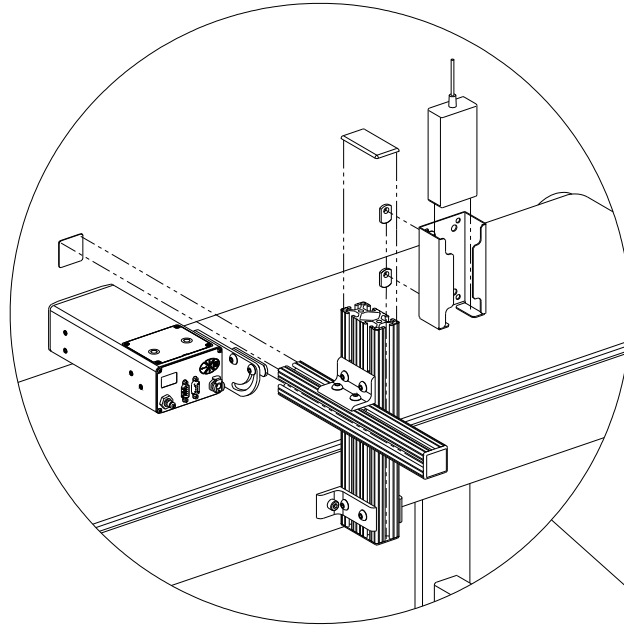

Ensure bar is behind front face of print head

Step 4: Install Pressurized Ink Can Supply and Controller

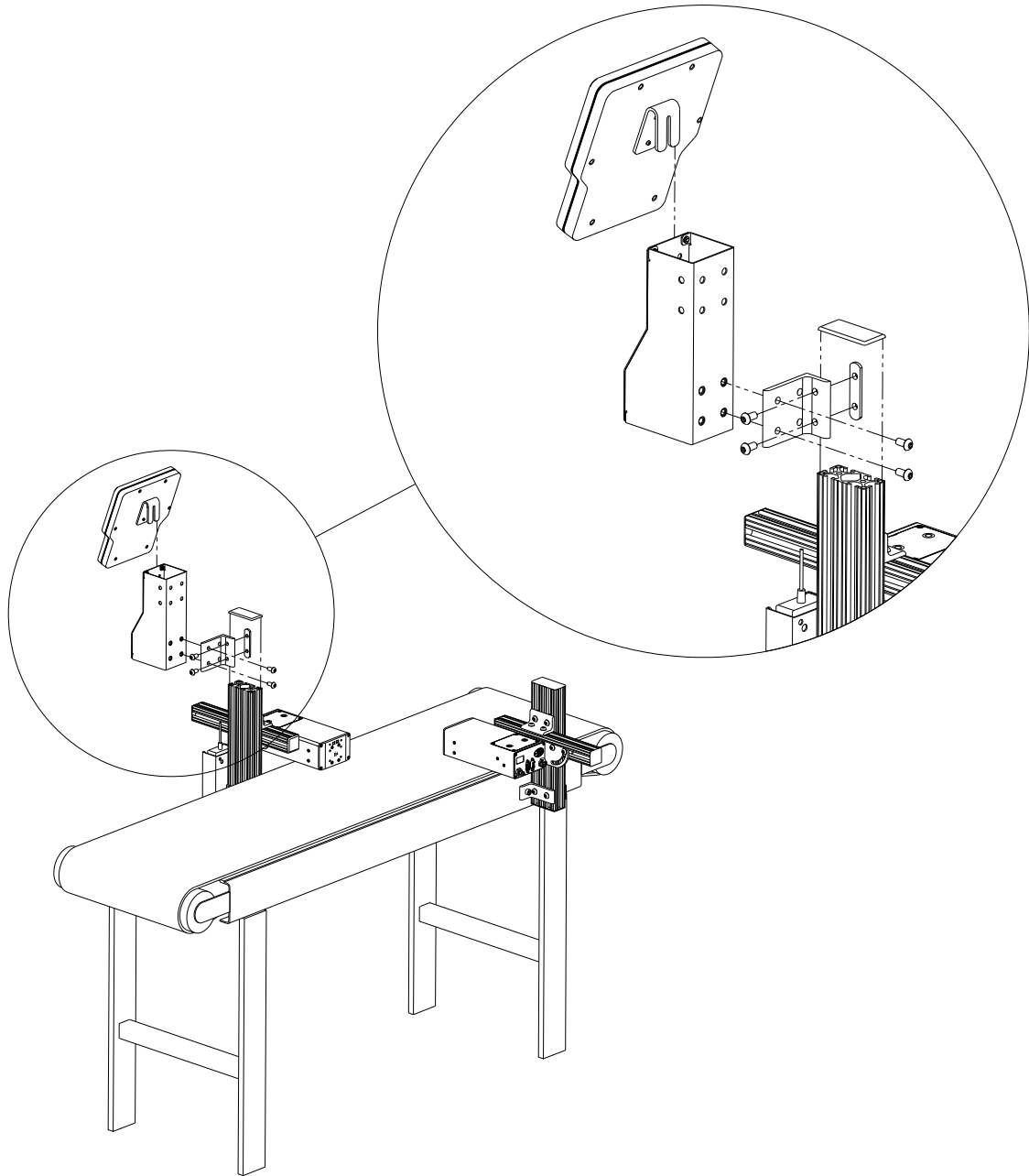

**CAUTION: DO NOT
INSTALL PRESSURIZED
INK CAN YET. All tubing
connections must be made
first.**

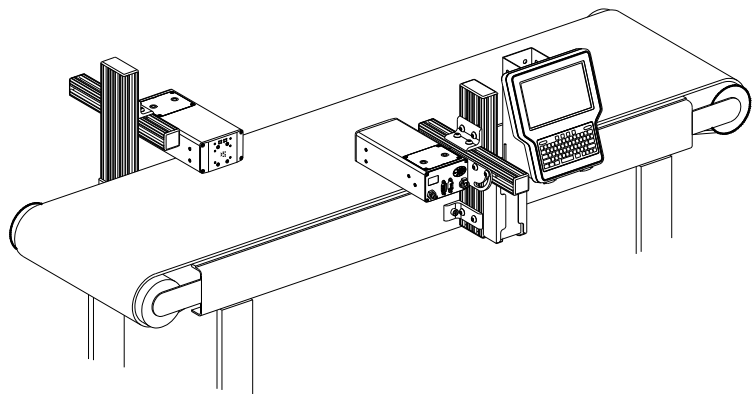

Step 5: Adjust Print Head to Substrate

Adjust print head vertically to meet requirement.

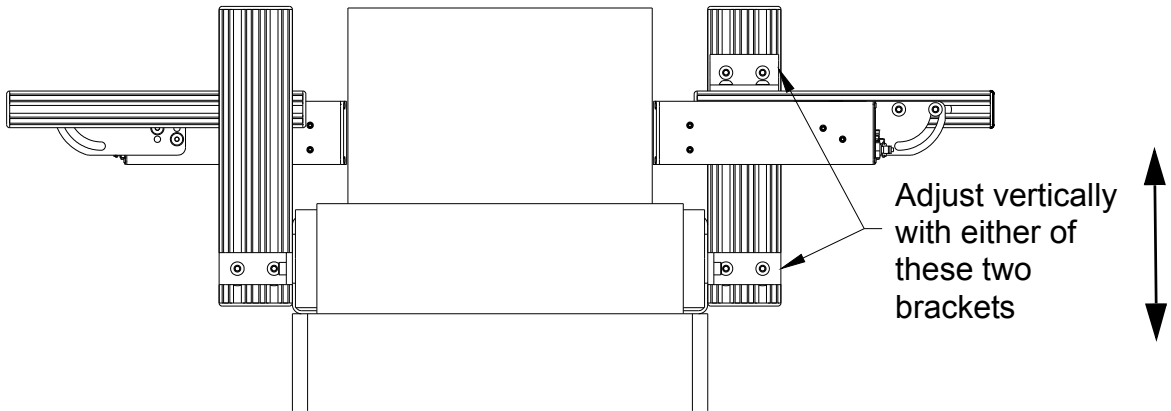

Adjust print head horizontally to set print gap.

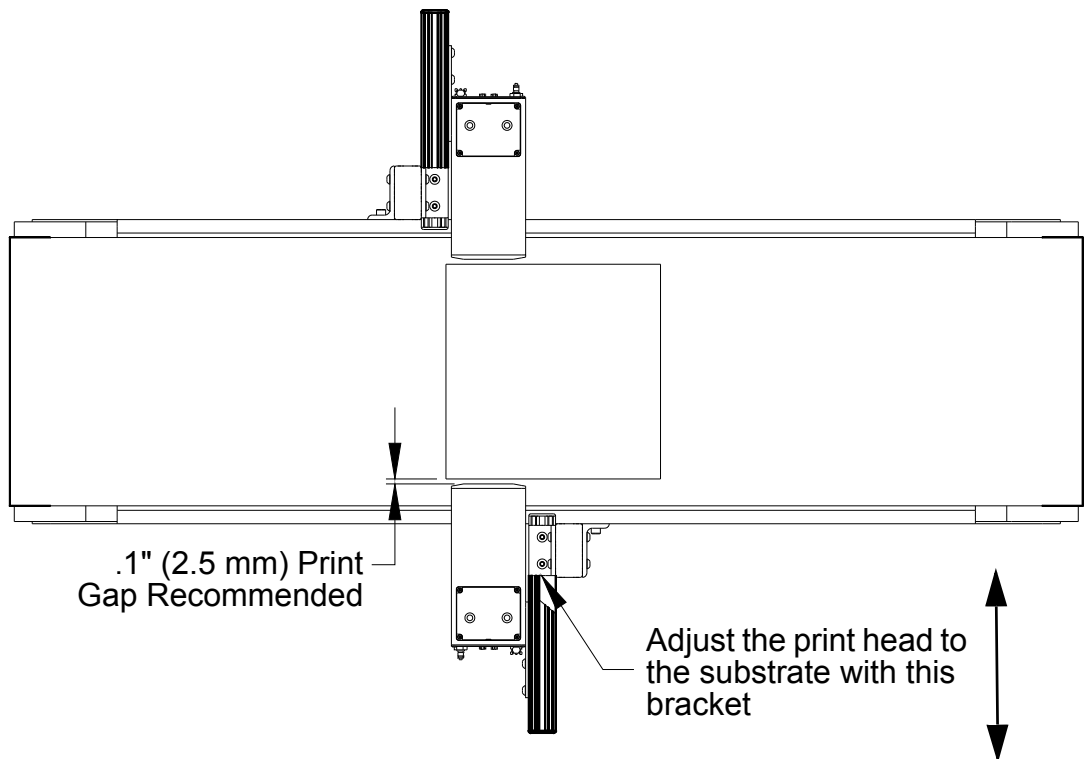

Step 6: Install Tubing



CAUTION: DO NOT INSTALL PRESSURIZED INK CAN YET. All tubing connections must be made first.

1. Install / route tubing per diagram below.
2. Insert quick-disconnect fittings at each open end of the tubing. One quick-disconnect fitting is supplied with the pressurized ink can system, and an additional fitting is supplied with each print head.
3. Remove plug from the exit port of the regulator.
4. Insert the tube / quick-disconnect fitting into the appropriate open ports on the ink supply and print head(s).

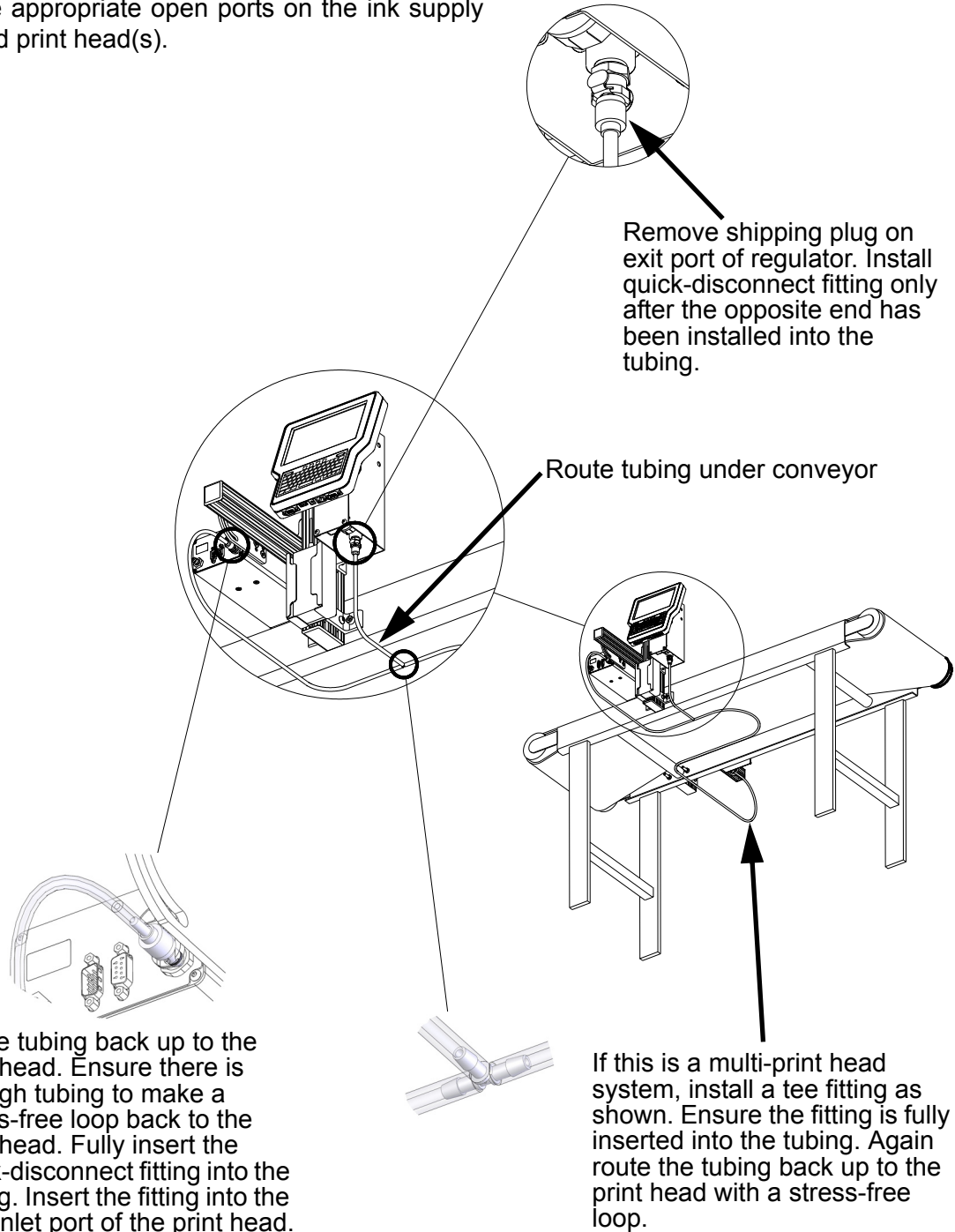

Step 7: Electrical Connections



CAUTION: Power should be disconnected from the controller prior to connecting or disconnecting any external device, including print head daisy chain cables or ancillary cables for a photocell, encoder, etc. Electrical arcing may occur if external cabling is connected or disconnected while power is supplied to the unit.

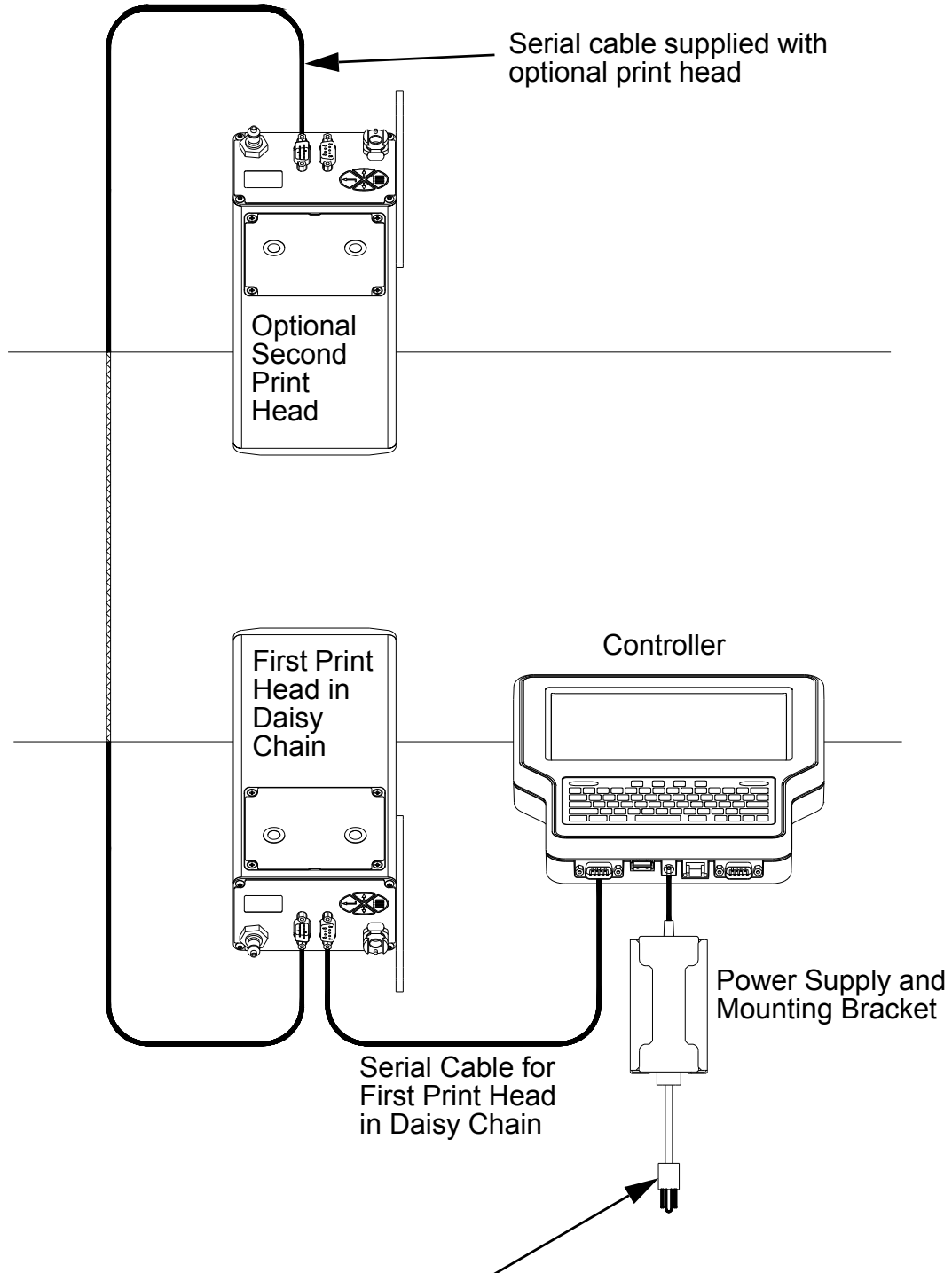

After making all other electrical connections, connect the included power supply to the AC mains (100V - 240 VAC). The controller will turn on and an LED light will show up on all print heads. After power and boot up, the controller will start on the home screen.

Step 8: Bleed Ink Lines and Print Heads

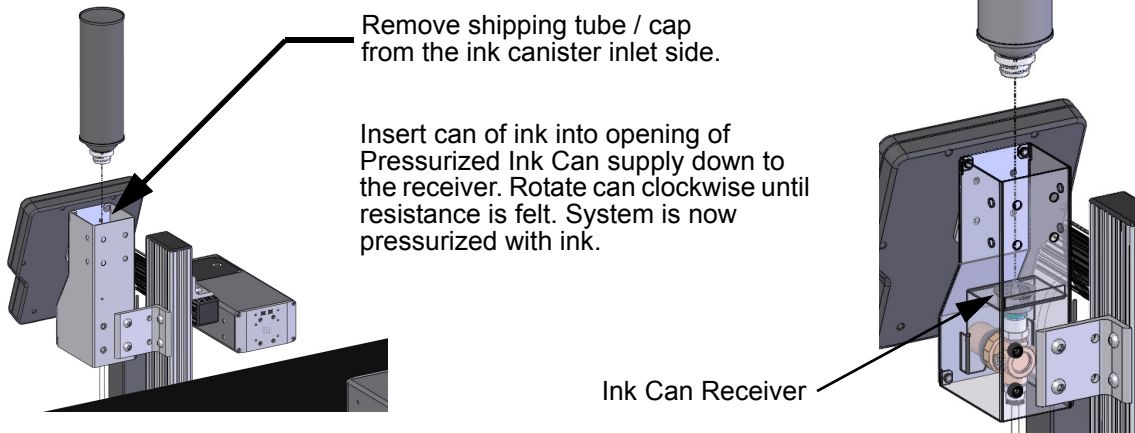

CAUTION: Ensure that the shutoff valve on the effluent bottle system is closed prior to connecting to the last print head in the daisy chain.

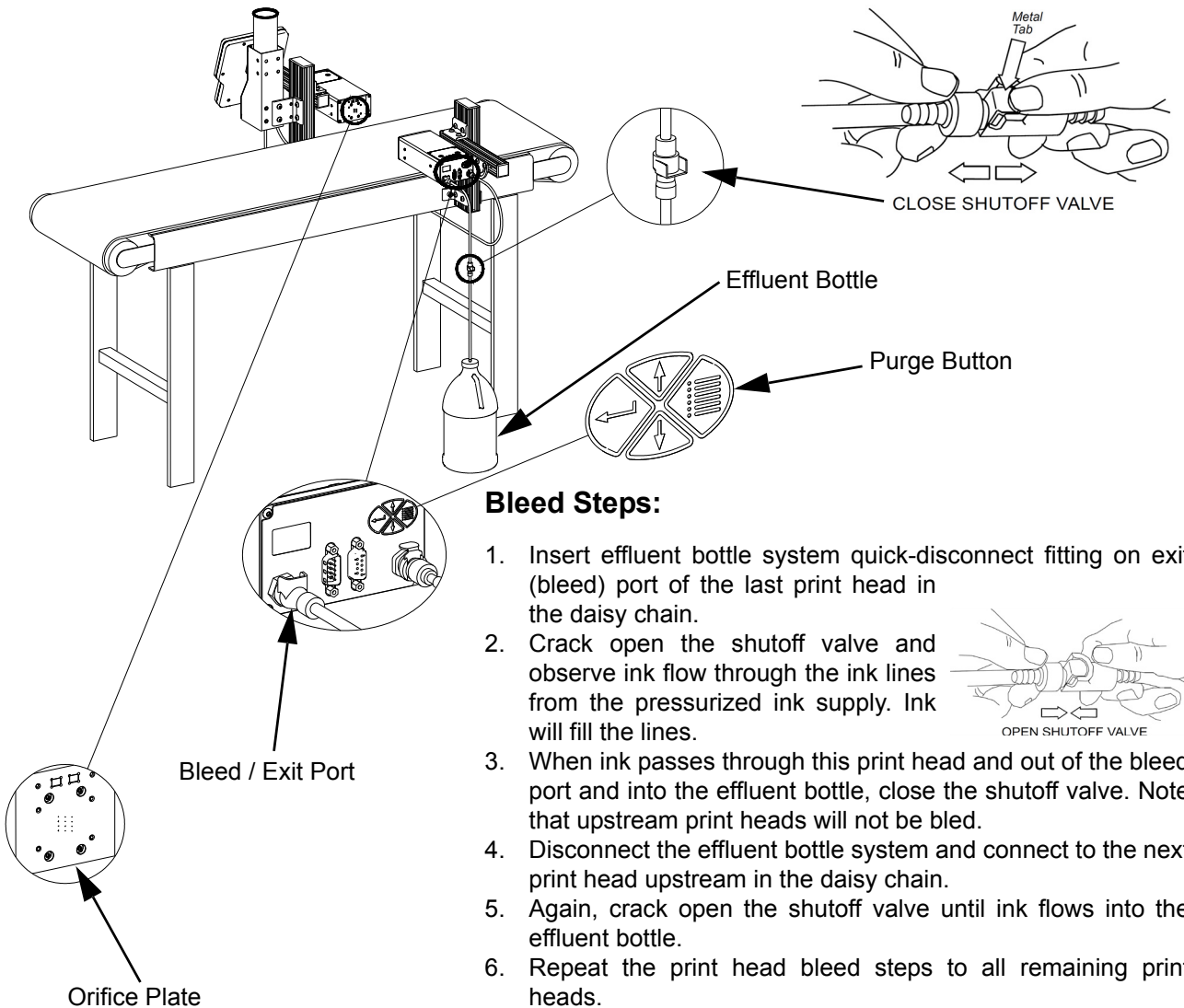

Bleed Steps:

1. Insert effluent bottle system quick-disconnect fitting on exit (bleed) port of the last print head in the daisy chain.
2. Crack open the shutoff valve and observe ink flow through the ink lines from the pressurized ink supply. Ink will fill the lines.
3. When ink passes through this print head and out of the bleed port and into the effluent bottle, close the shutoff valve. Note that upstream print heads will not be bled.
4. Disconnect the effluent bottle system and connect to the next print head upstream in the daisy chain.
5. Again, crack open the shutoff valve until ink flows into the effluent bottle.
6. Repeat the print head bleed steps to all remaining print heads.
7. Hold and absorbent towel over the orifice plate at the front of any print head and press the purge button on the rear of the print head until ink is observed on the towel.
8. Repeat step 7. on all other print heads.

Step 9: Configure the Print Head via Controller

Ensure the home screen menu is present on the controller via the **Hide Menu / Show Menu** button, and then press the **Control Panels** button.

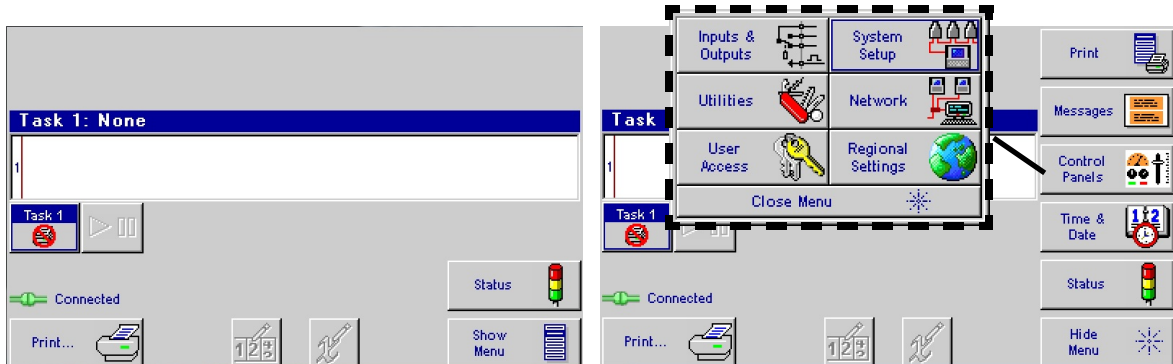

Press the **System Setup** button. On the **Print Heads** page, press the **Redo Print Head Setup** button. Select the desired direction.

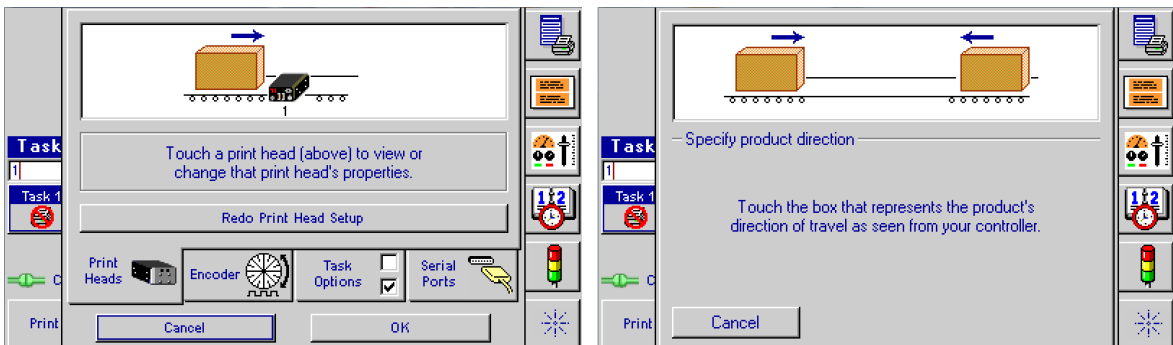

Set the number of print heads and identify their positions relative to the controller.

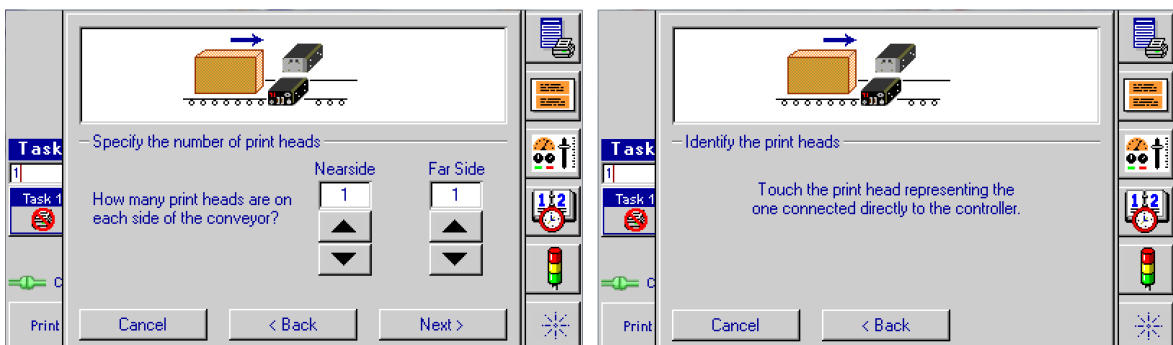

Print head setup complete. Next, select the Encoder tab, and ensure the fixed speed encoder type is selected. Touch the speed input box and type in the line speed. If more precise line speed is desired, then an optional external encoder is available.

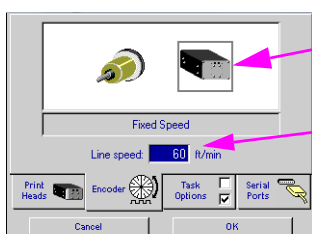

Fixed Speed:
User types in the desired line speed

Touch this box, then type in the desired speed

Optional External Encoder:

Line speed measured by an externally mounted encoder and connected to the last print head in the daisy chain via an adaptor cable. See "Optional Equipment" on page 49.

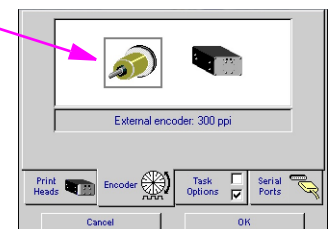

Step 10: Create a Message

From the home screen, select the **Messages** button and then the **New** button to enter the message editor.

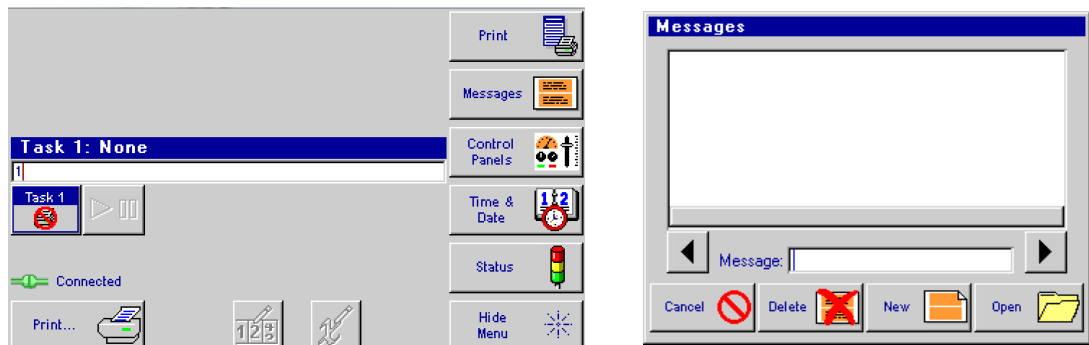

Create and save the message, and then exit the message editor.

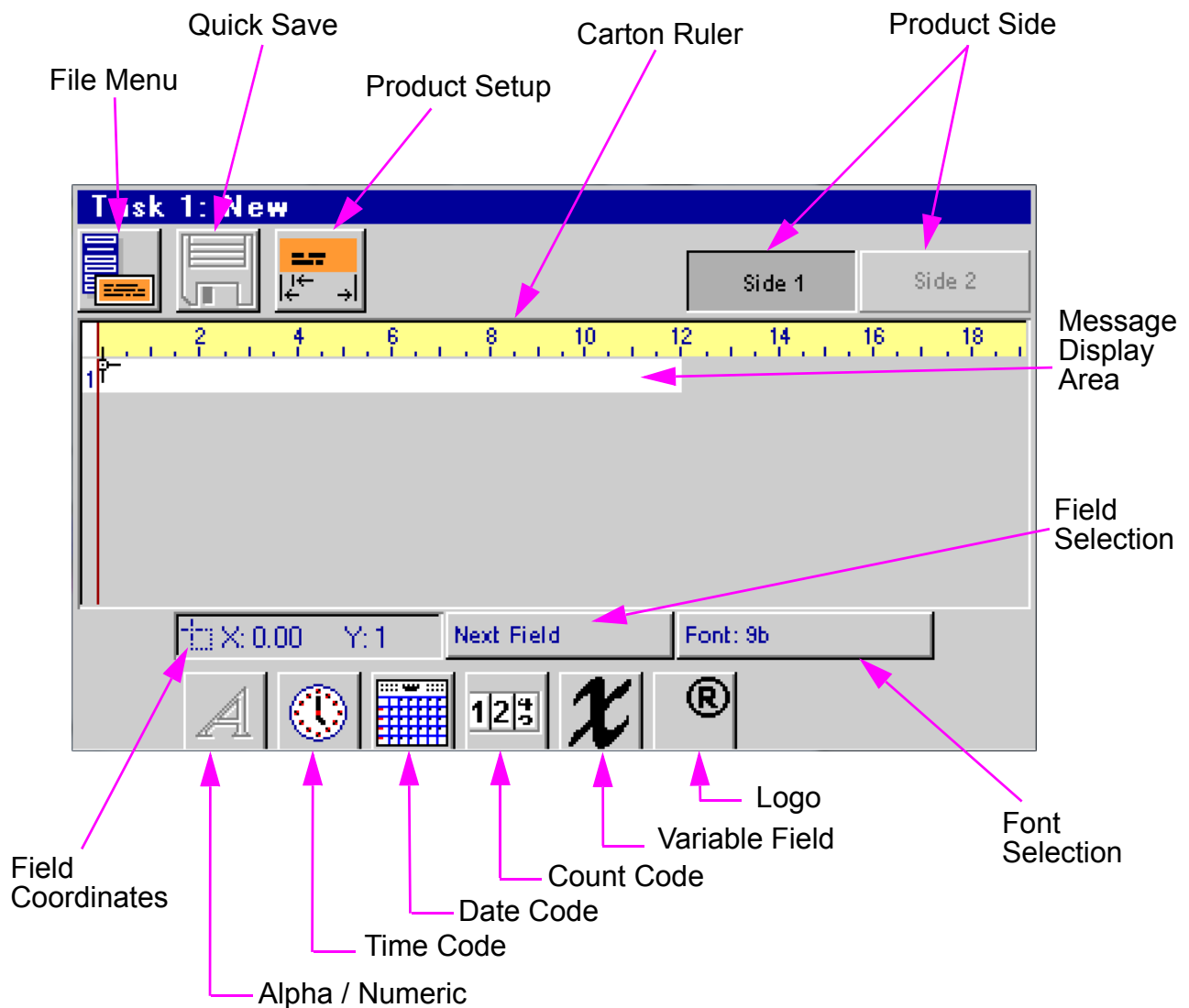

Step 11: Print a Message

From the home screen, press the **Print** button.

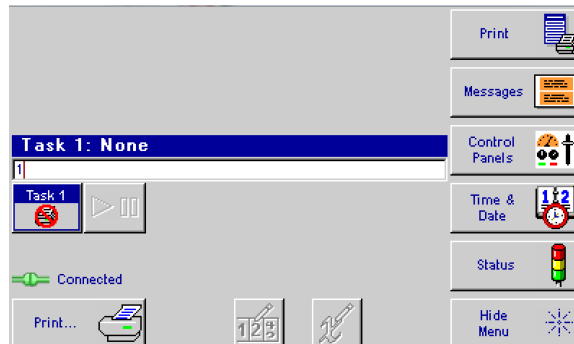

Select the desired message to print, and press the **Print It** button.

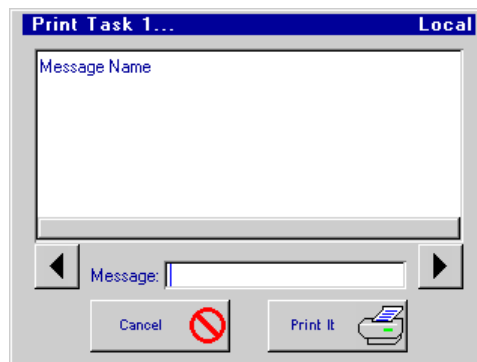

The message will print on the next photocell trigger.

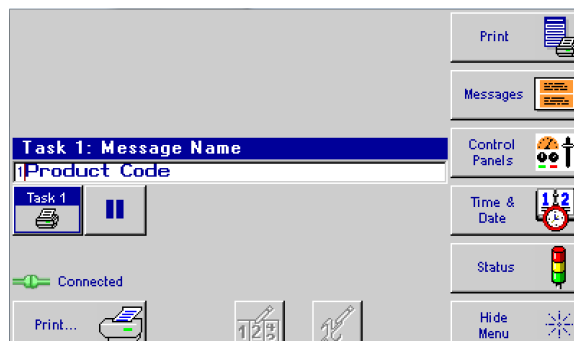

Section 3: Handheld Controller

Keypad

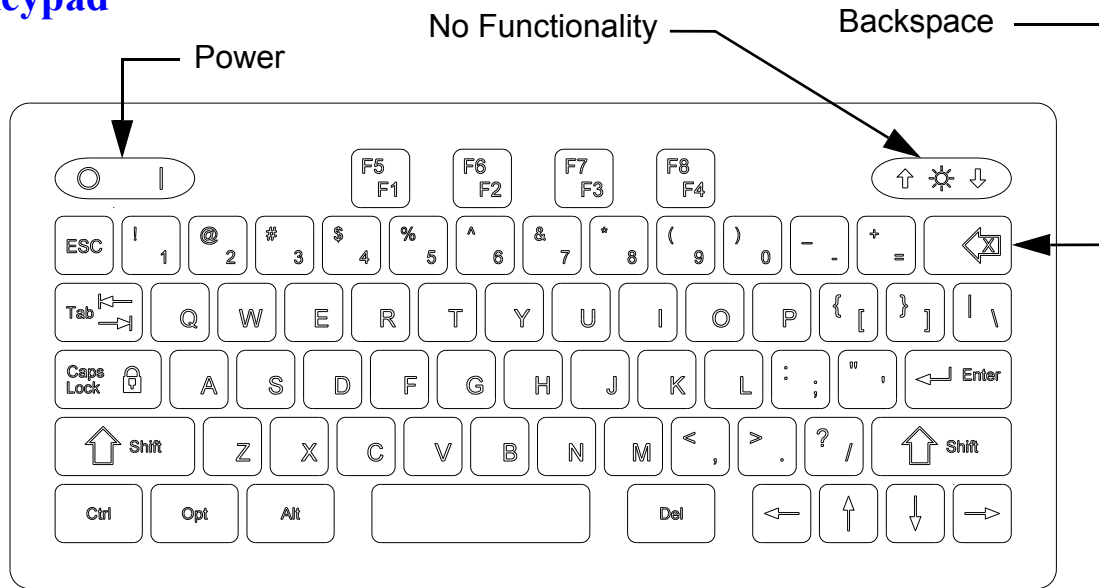

ESC (Escape):

- Closes the current window, a dialog box, or menu.
- Restores the original contents of any input entry box, if **Enter** has not been pressed.

Arrow Keys:

- Shifts focus between screen controls.
- Moves highlighted fields or the cursor around in the Message Editor.

Tab:

- Shifts focus between screen controls.
- Shifts focus between fields in the Message Editor.

Backspace in Message Editor:

- Normal functionality as QWERTY keyboard.
- Deletes a highlighted field.

Ctrl (Control) in Message Editor:

- Amplifies the movement of the arrow keys.
- Holding the Ctrl key while pressing the Enter key at the end of a text line enables paragraph functionality.
- Ctrl + C copies a highlighted field and has comparable behavior to a personal computer.
- Ctrl + X cuts a highlighted field and has comparable behavior to a personal computer.
- Ctrl + V pastes a previously copied or cut field and has comparable behavior to a personal computer.

Function Keys:

- **F1 / F2** keys scroll the screen left and right on the Home screen and the Message Editor, respectively.
- The **F4 / F8** keys pull up the extended characters dialog inside the Message Editor.

Home Screen

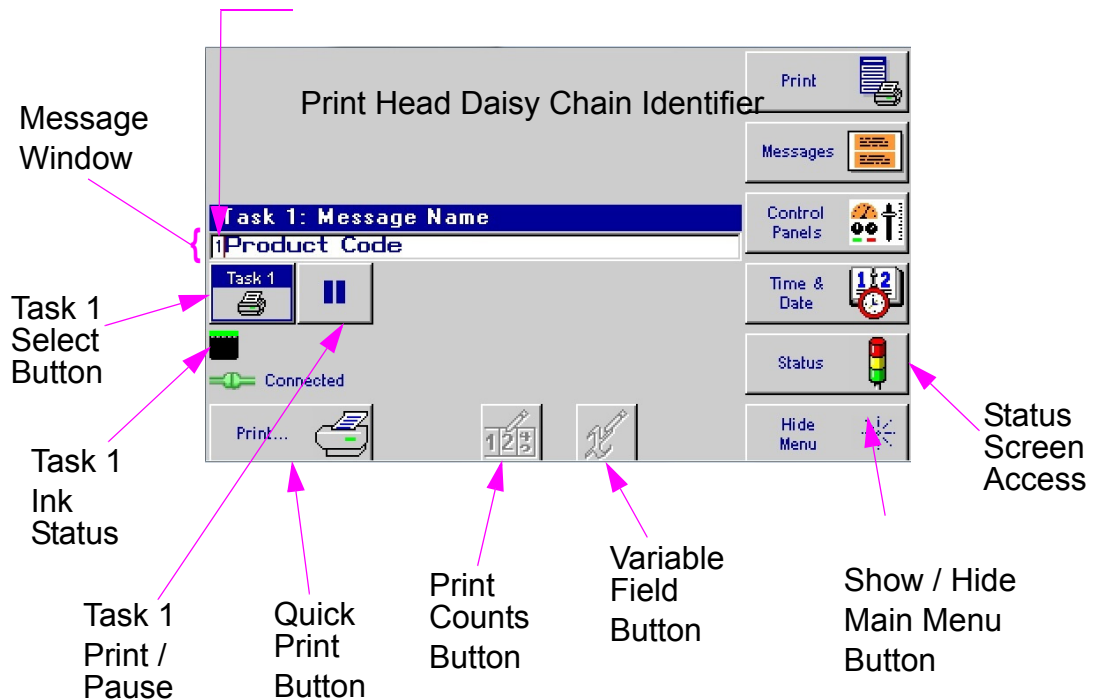

Message Window:



- Displays the current print message.
- Updated approximately every seven seconds, so it likely will not show each print.
- Long print messages can be viewed by using the **F1** and **F2** keys to scroll the message left and right, respectively.
- White or beige bars represent a print head in the daisy chain and are identified by their respective numbering.
- The header displays the task number and file name of the message being printed. If no message is loaded to print, "**None**" is displayed.

Task Select Button:



- Places focus on the selected task. This allows one to view what is being printed on either task in the home screen. Additionally, items in the main menu vary from one task to the other.

Task Print / Pause Button:

Play State
Press to
Pause



- Starts and Stops print after an operator response to a confirmation dialog popup box.
- If a message is currently printing, pressing the **Pause** button will discontinue printing after the message completes printing.
- If the **Play** button is pushed, print will resume on the next product detected.

Pause State
Press to
Print

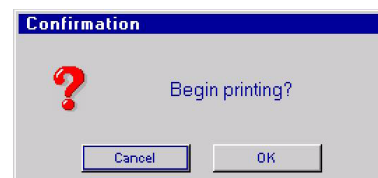
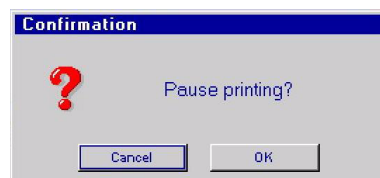

Quick Print Menu Button:



- Allows one to access the **Print** dialog box directly, even with Restricted User Access enabled.
- Simply select the desired message and press the **Print It** button. The message will print at the next photocell trigger.

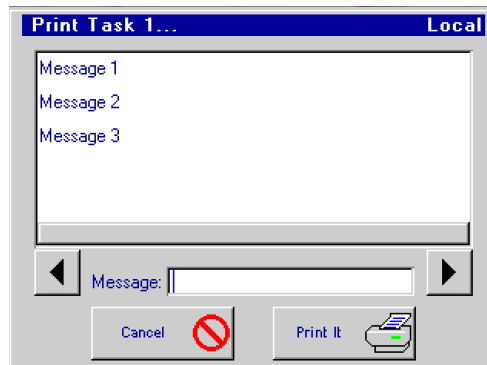

Counter:



- Count codes are allowed, but one must select the "Print" button to adjust the count.

Variable Field:



- Variable information fields are allowed, but one must select the "Print" button to change the information being printed.

Ink Status:



- Reports the ink status as OK for pressurized ink cans only.



- Reports the ink status as Low / Empty for pressurized ink cans only.



NOTE: The optional bulk ink system does not report ink status through the controller. Bulk ink status is reported through its beacon.

Main Menu

Main Menu Collapsed

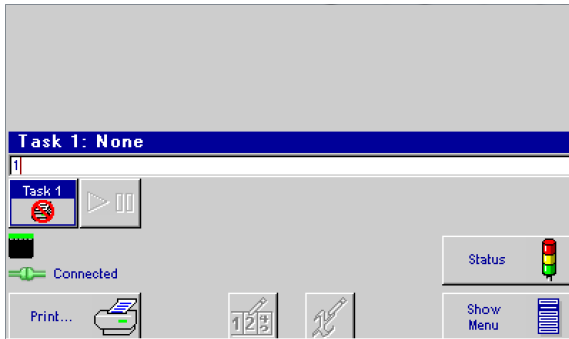

Main Menu Expanded

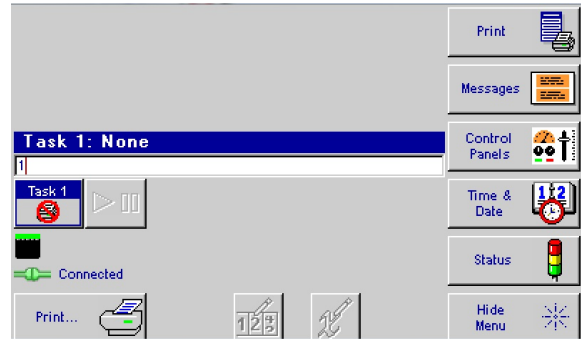

Print Menu

Print Menu Button

Cancels print immediately after a confirmation popup dialog box

Closes this menu immediately

NOTE: The Variable Field button is not available. In order to update a variable field, reselect the message to Print.

Fires all jets for a short period of time on the selected print head

Returns to Home Screen

Messages Dialog & the Message Editor

Messages Dialog

Message List

Selected Message

Opens Selected Message in the Editor

Returns to Home Screen

Deletes a Selected Message

Starts a new message in the Editor

Integrated Valve

Section 3: Handheld Controller

Message Editor

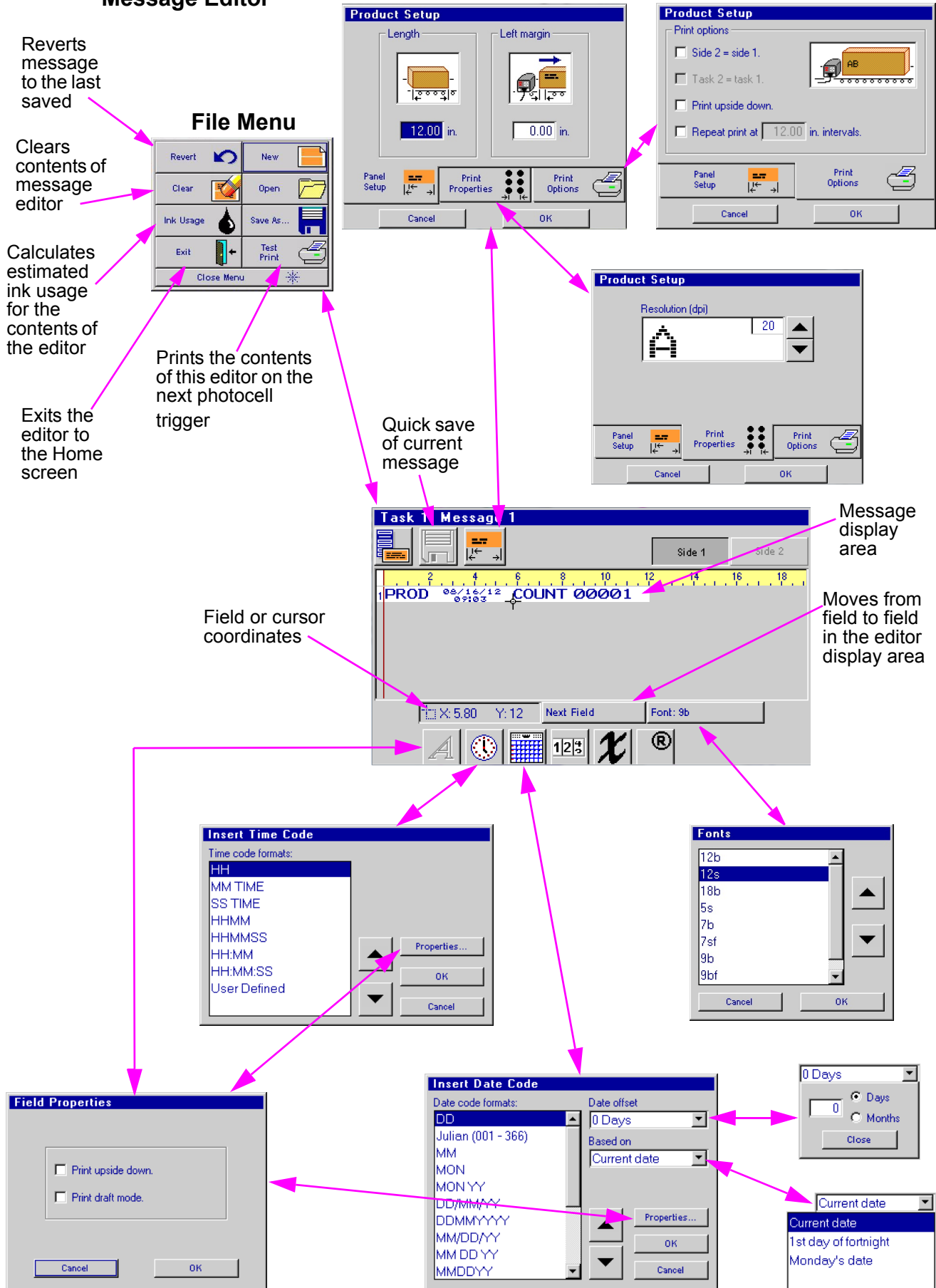

Message Editor continued: User Defined Time Codes

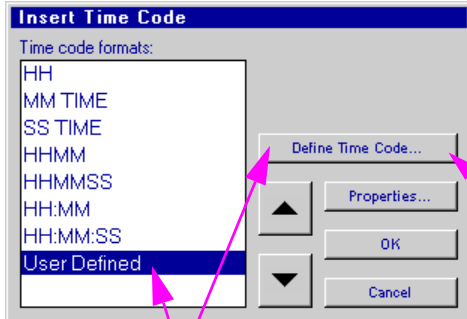
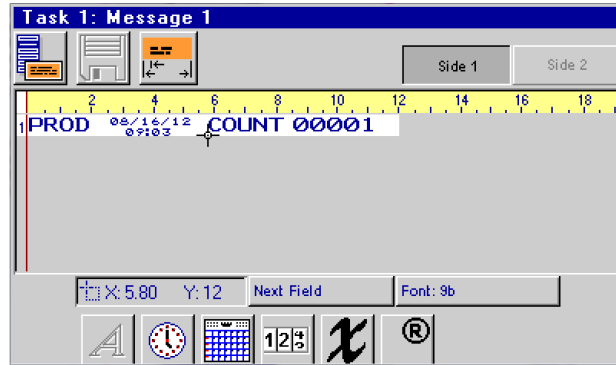

When **User Defined** selected, **Define Time Code** button appears

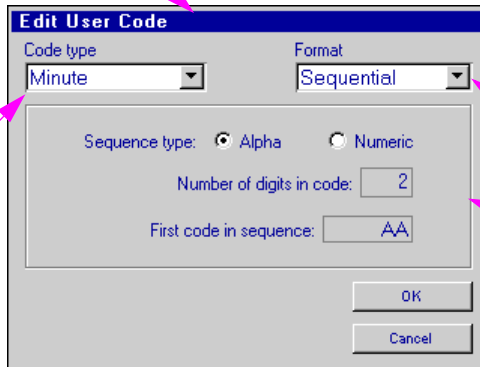
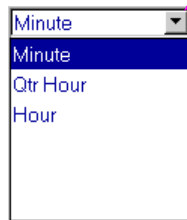

Sequential format: minute code shown.
Minute 00 = AA, 01 = AB, 02 = AC, etc.

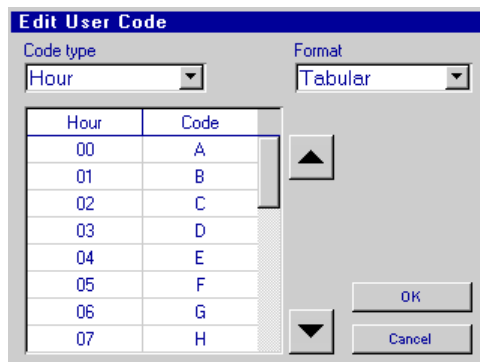
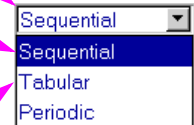

Tabular format: codes printed taken from table. Use default codes (default Hour codes shown) or edit table to suit your requirements.

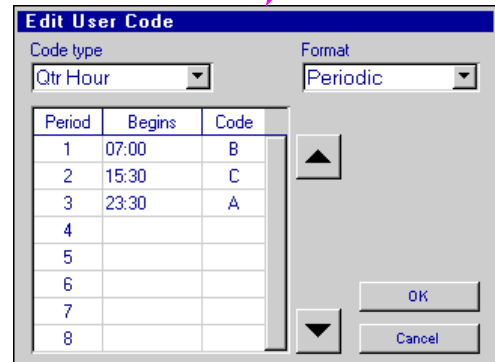

Periodic format: example above illustrates a shift code implemented by using a periodic quarter hour code. 'A' prints from 23:30 -06:59, 'B' from 07:00 - 15:29, and 'C' from 15:30 - 23:29.

Message Editor continued: User Defined Date Codes

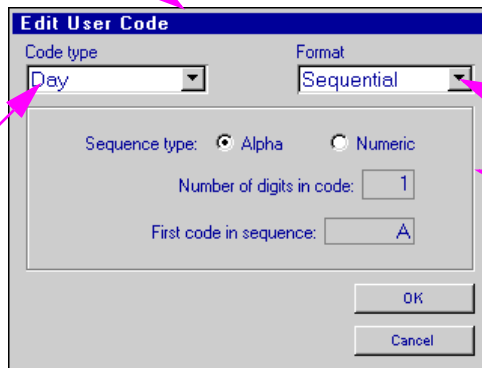
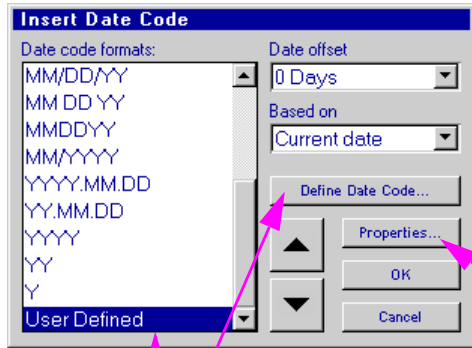
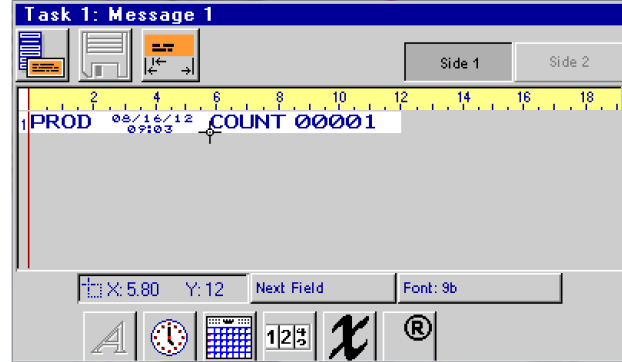

When **User Defined** selected, **Define Date Code** button appears

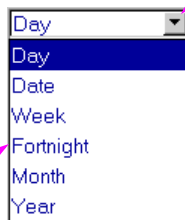

The **Fortnight** code type is available for the **Tabular** format only

Sequential format: in example above Sunday = 'A', Monday = B, etc

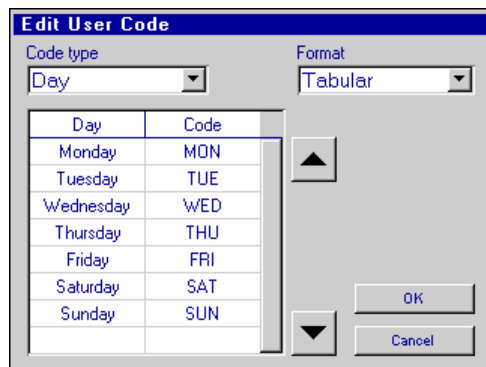

Tabular format: codes printed taken from table. Use default codes (default Day codes shown) or edit table to suit your requirements

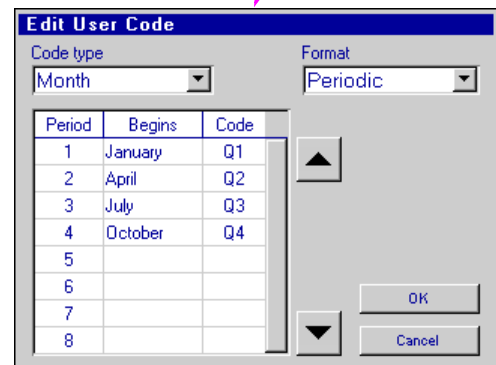

Periodic format: example above illustrates a quarter year code implemented by using a periodic month code. 'Q1' prints from Jan 1 - Mar 31, 'Q2' from Apr 1 - Jun 30, etc.

Message Editor continued: Product Counts, Variable Fields, Logos

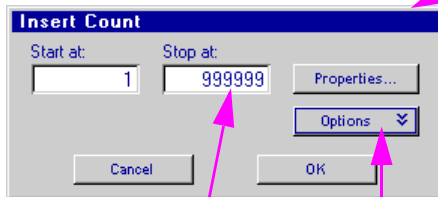
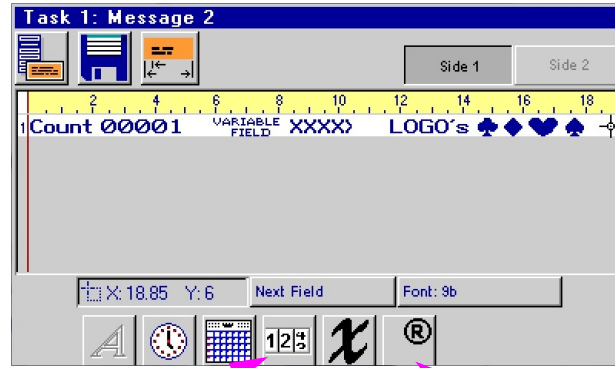

Maximum 9-digit count

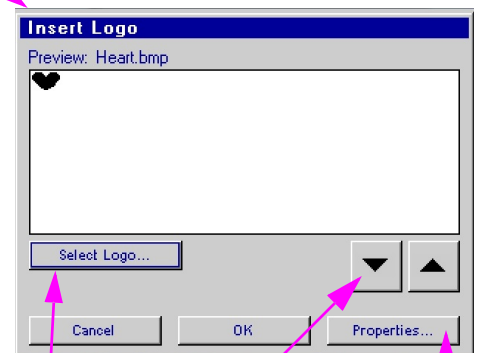
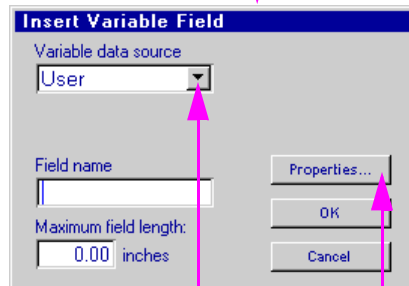

Scroll through logo images or select from list

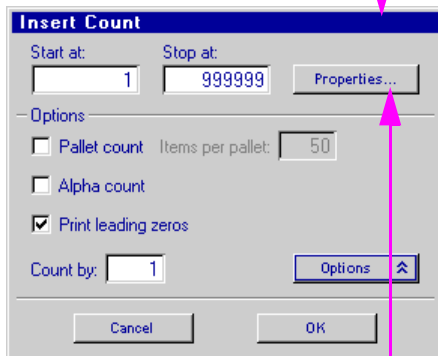

Incrementing Count

Count increments when the 'Start at' value is less than the 'Stop at' value.

Decrementing Count

Count decrements when the 'Start at' value is greater than the 'Stop at' value.

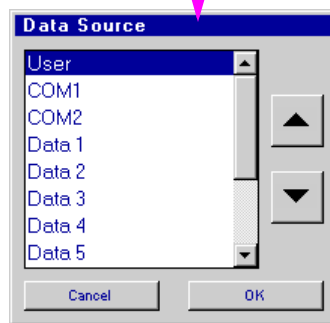

Variable Field Data Source

User: Print data entered when print message containing the variable field is selected to print.

COM1, COM2: Data is received through COM1 or COM 2 serial port. Data must be received before the message is selected to print.

Data 1 - 10: Data is retrieved from corresponding system variable. User has the option to change the data when the message is selected to print.

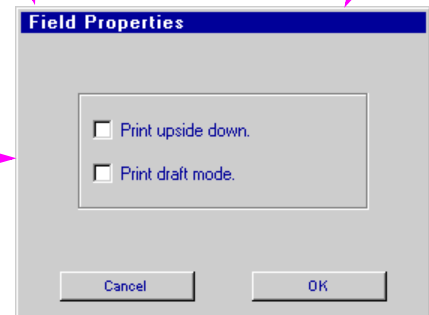
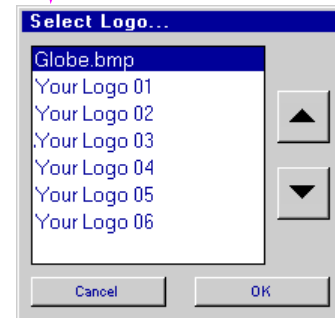

Control Panels Menu

I/O feature not available on Handheld

System Utilities menu for miscellaneous controller tools and file management

Security Access

Controls print head and ancillary equipment configuration

Configures network connectivity via the Ethernet port

Language and unit of measure configuration

Closes this menu immediately

System Setup:

NOTE: The **Product sensor offset** is only available when **External product sensor** is selected on the **Task Options** tab. **NOTE:** Product sensor offset equals 2.7 in (68.6 mm) if mounted to the side of the print head.

Optional External Encoder:
Line speed measured by an externally mounted encoder and connected to the last print head in the daisy chain via an adaptor cable. See "Optional Equipment" on page 49.

Set print direction, number and type of print

System Setup Screen

Port	Baud	Function
COM1	57600	Serial Print Head - IV: Task 1
	57600	None

Fixed Speed:
Enter the desired line speed

Optional externally mounted photocell: Connect to the last print head in the daisy chain via an adaptor cable. See "Optional Equipment" on page 49.

COM port configuration options

Network:

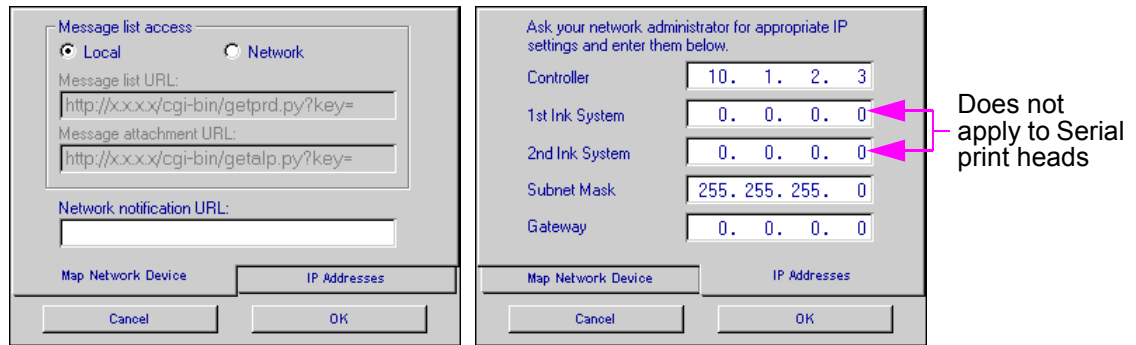

Regional Settings:

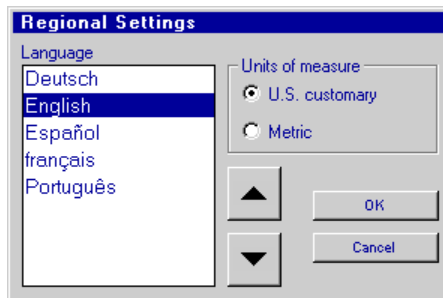

User Access:

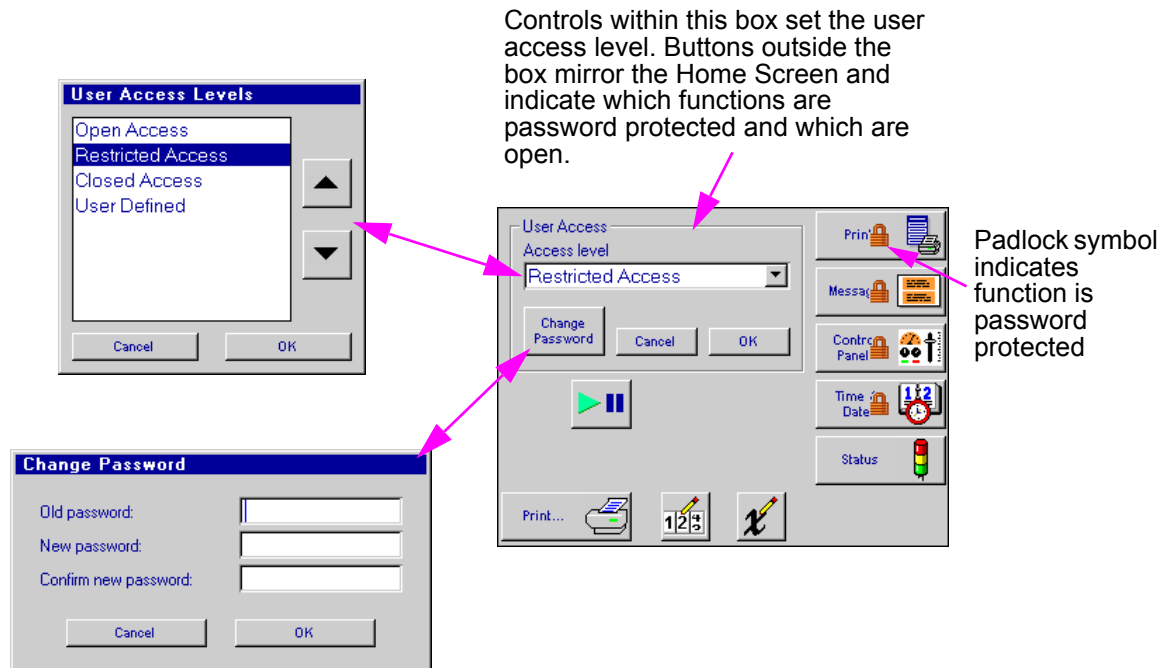

The factory set password is **Manager**.
 Passwords are case sensitive.

Utilities:

After performing the **Restore default configuration** function, the serial port must be reconfigured for a serial print head.

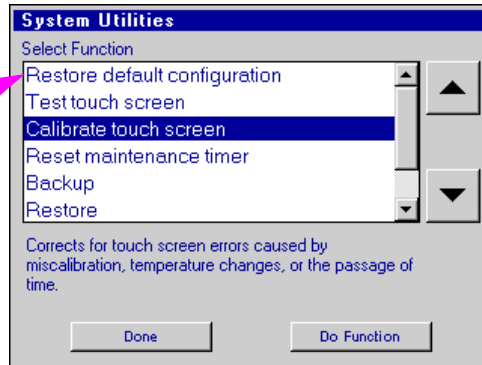

Time & Date Setting Screens

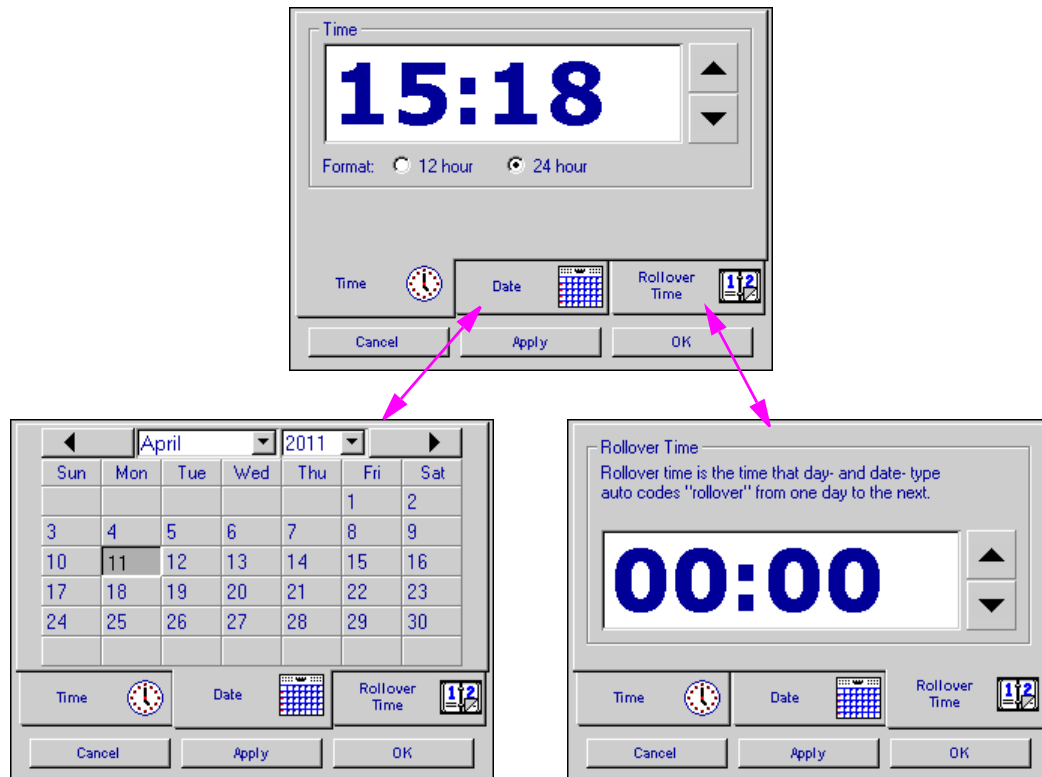

Status Screen

Note: This set of status screens represents two print heads setup in a daisy chain. The first print head is properly connected and detected. The second print head has not been properly connected to the daisy chain.

One button for each print head in the daisy chain. Press button to display status for that print head & cartridge.

Right hand photocell (as seen from front of print head) covered and the left is not

Printing is enabled

Ink can - OK

Date (Y-M-D) and time from print head

Print head firmware version number

Controller / GUI version number

List of fonts and logos on the print head

Indications that head 2 is improperly connected or not communicating with the controller

No date & time

No print head firmware version number

Font and logo list is empty

Section 4: Print Head Functionality

Home Screen:

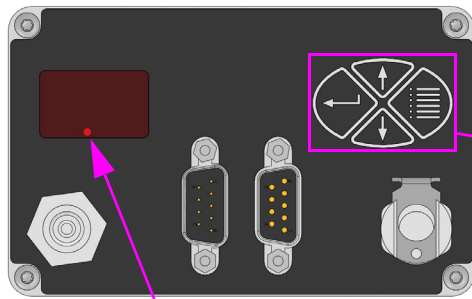

LED Power Indicator

Up Arrow:
Scrolls up a list or increases pulse width

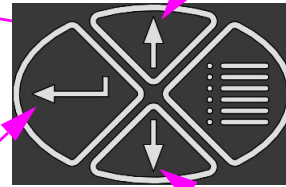

Purge Button:
Ejects ink from all or individually selected channels

Enter Button:
executes a command

Down Arrow:
Scrolls down a list or decreases pulse width

Pressure Screen:

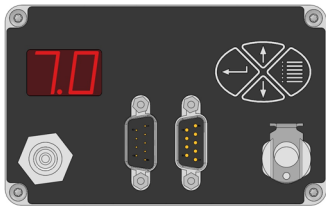

- Pressing the Enter button from the Home Screen displays the ink pressure in psi on the inside of the print head (e.g. 7.0 psi)
- After 30 seconds, the display returns to the Home Screen.

Print Head Purge:

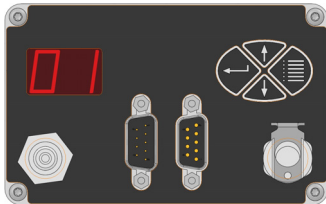

- Press and hold the Purge button for 1 second at the above Pressure screen and all channels will fire dots for 2 seconds if the Purge button is released.
- Holding the Purge button continuously will fire all channels until released.
- If the Enter button is pushed from the Pressure screen, then an individual channel is displayed (e.g. channel 1).
- Individual channels can be selected using the up and down arrows. Pressing the Purge button will only eject ink for the individual channel selected.
- To return to the Home screen, press the down arrow until the "Pr" (Pressure) screen is reached, and then press the Enter button.

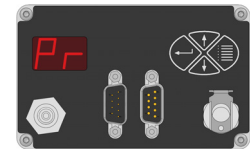

Pulse Width (Printed Dot Size) Adjustment:

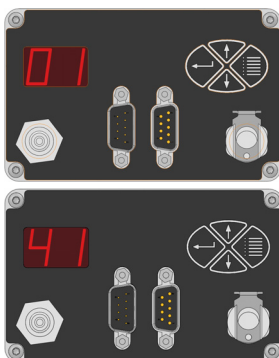

- From the Home or Pressure screen, simultaneously press the Up and Down arrows. The last active channel will display (e.g. channel 1).
- Select the desired channel to change the pulse width using the Up and Down arrows.
- Press the Enter button.
- The current pulse width value is displayed (e.g. 41).
- Use the Up and Down arrows to increase or decrease the pulse width.
- Press the Enter button to save the change. If the Enter button is not pressed within 30 seconds, then the pulse width is not changed.

Section 5: Maintenance & Shutdowns

The following are the recommended maintenance procedures to keep the ink jet system printing cleanly and efficiently.

System Maintenance

Intermittent (as required):

5. Be sure the photosensor is clean and free of debris.
6. Be sure the O-rings on the encoder wheel are present and not worn (cracked and/or chipped).
7. Be sure the nuts and bolts holding the bracketry in place remain tight.
8. Equipment may be cleaned utilizing the appropriate conditioner for the ink in use. See “System” on page 47.



CAUTION: Do not spray conditioner on, or wipe off, exposed electrical connections.

Annually:

1. Replace encoder O-rings (refer to “Optional Equipment” on page 49).
2. Recalibrate Touch Screen.

Print Head Maintenance

Daily Startup



Wear safety goggles when working with industrial inks or solutions!

1. Clean print head faceplates with the appropriate conditioner for your ink system. Spray conditioner on a lint-free wipe and wipe the faceplate in a circular motion to remove ink from the orifices. Maintenance sprays are conveniently packaged in pressurized cans. See “Consumables” on page 47.
2. Inspect lines and connections for leaks. Make repairs if needed.
3. Inspect all electrical connections and cabling for damage, and replace as necessary.

Preventative Maintenance at 2000 Hours

- Thorough cleaning of print head
- Solenoid and pulse-width adjustment for optimal dot size

Shutdowns of Seven Days or Longer

For extended shut down periods, it is recommended that the print head(s), regulator(s) and the optional ink delivery system be thoroughly flushed with appropriate conditioner. In order to perform this procedure, an adequate supply of conditioner and an additional cap assembly for the optional ink delivery system are required. Refer to “Consumables” on page 47.

1. Remove the ink.
2. Install the can of conditioner / solvent.
3. Connect an effluent bottle system as discussed in “Section 2: Quick Start”.
4. Perform the “Bleed Steps:” in “Step 8: Bleed Ink Lines and Print Heads” on page 14.

Section 6: Troubleshooting

NO PRINT

Symptom	Possible Cause	Actions
No print head power / red LED on rear of print head	<ul style="list-style-type: none"> Power Supply AC Source 	<ul style="list-style-type: none"> Check power supply light indicator. Check for AC power source between power supply input limits.
Pressure is low indicated by an "Ink Low" or "Ink Out" on the controller	<ul style="list-style-type: none"> Ink can is empty Regulator is set low or malfunctioning 	<ul style="list-style-type: none"> Replace with new can of ink. Refer to "Ink Regulator Adjustment" on page 34.
Print head purges but won't print desired message	<ul style="list-style-type: none"> No print message on print head Controller or PC software not configured for Serial Print Head Encoder Malfunction Product not triggering photocell. 	<ul style="list-style-type: none"> Ensure the desired print message appears on the controller home screen. If not, reselect message to print. Configure task to serial print head. Refer to "Appendix B: Serial Port Setup" on page 40. Ensure encoder is installed and plugged into the last print head in the daisy chain. Ensure the product is within 1/4" of the front face of the print head. If an external photocell is installed, then validate the setting from the Control Panels, System Setup, Task Options tab. Ensure print head photocells are clean.

POOR PRINT QUALITY

Symptom	Possible Cause	Actions
Print is splattered or excessive satellites	<ul style="list-style-type: none"> Print head is mounted too far away from the substrate Pulse width(s) are set too high Print head pressure set too high 	<ul style="list-style-type: none"> Adjust the print head to within specifications. See "Step 5: Adjust Print Head to Substrate" on page 11. See "Print Head Purge:" on page 30 of "Section 6: Troubleshooting". Refer to "Ink Regulator Adjustment" on page 34.
Dot columns are out of alignment	<ul style="list-style-type: none"> Product speed and print speed are not matched External encoder malfunction 	<ul style="list-style-type: none"> From the controller Home Screen, press the Control Panels button, System Setup button, the Encoder tab, and then make sure the Fixed Speed matches the actual line speed. Ensure the encoder wheel is properly tracking the belt and not bouncing. Ensure encoder o-rings are not worn, cracked, or broken.
Dot size variation or missing dots	<ul style="list-style-type: none"> Regulator is set low or malfunctioning Pulse width set too high or low Clogged or covered orifices 	<ul style="list-style-type: none"> Refer to "Ink Regulator Adjustment" on page 34. Refer to "Pulse Width (Printed Dot Size) Adjustment:" on page 30. Clean the orifice plate (See "Daily Startup" on page 31), and broach any orifice as necessary. See "Tools and Maintenance" on page 49 for broach kit.
Static seepage (ink seeping out of orifices when not printing)	<ul style="list-style-type: none"> High ink pressure Incorrect pre-load 	<ul style="list-style-type: none"> Refer to "Ink Regulator Adjustment" on page 34. See "Adjusting Solenoid Pre-load" on page 34.
Dynamic seepage (ink seeping out of orifices during print)	<ul style="list-style-type: none"> Pulse width set too low Low ink pressure Incorrect pre-load Expired ink 	<ul style="list-style-type: none"> Refer to "Pulse Width (Printed Dot Size) Adjustment:" on page 30. Refer to "Ink Regulator Adjustment" on page 34. See "Adjusting Solenoid Pre-load" on page 34. Replace ink and bleed new ink through system (see "Step 8: Bleed Ink Lines and Print Heads" on page 14).

Ink Regulator Adjustment



NOTE: The regulator installed inside the pressurized ink can system comes from the factory adjusted to the correct pressure. However, occasionally it may need to be adjusted for a change in pressure or has drift issues. **DO NOT** adjust the regulator for the purpose of increasing any or all dot sizes. The regulator should always be set to 7.0 +/- .3 PSI while not printing.

1. Remove the controller from the Pressurized Ink Can enclosure and place on a nearby stable object so it won't be damaged.
2. Remove the four screws holding the enclosure cover in place. The regulator is now exposed. Loosen the screw locking the regulator cap in place.
3. Connect an effluent system bottle to a nearby print head bleed port (see "Step 8: Bleed Ink Lines and Print Heads" on page 14) and ensure the shutoff valve is closed.
4. Open the shutoff valve and immediately turn the regulator knob clockwise fully (regulator full pressure).
5. Immediately turn the regulator knob counterclockwise fully until flow is shutoff.
6. Repeat steps 4. through 5. two more times.
7. Close the shutoff valve and remove the effluent bottle.
8. Adjust the operating pressure to 7.0 +/- .3 psi. Press the purge button on the rear of the print head. Observe the pressure on the rear of the print head after it has stabilized.
9. Make small adjustments until the correct operating pressure is achieved. The purge button must be pushed after each regulator adjustment.
10. If the regulator pressure never stabilizes, then it must be replaced. Refer to "Appendix H: Part Numbers" on page 47.

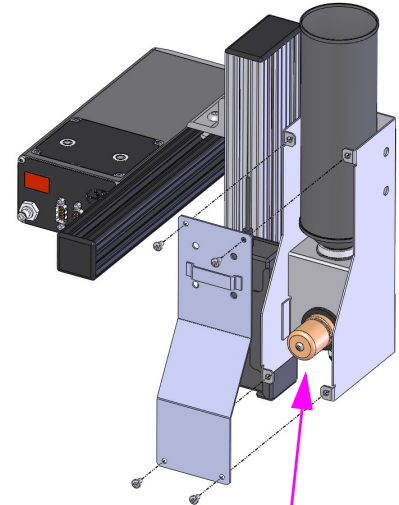

Ink regulator adjustment knob. Turn CW for more pressure and CCW for less.

Adjusting Solenoid Pre-load

1. If any of the orifices are seeping statically (not printing) or dynamically (while printing), then the appropriate channel pre-load may need to be adjusted.
2. Ensure the print head is powered and ink line connected.
3. Remove the enclosure cover, exposing the solenoid mounting block and adjustment nuts.
4. The regulator pressure should be set to 7.0 +/- .3 psi while not printing. Refer to the previous section, "Ink Regulator Adjustment" if it is not.
5. Thoroughly clean the front, orifice, plate with a clean non-abrasive cloth and maintenance spray, and then dry.
6. Hold a clean and absorbent cloth up to the front face of the print head and press the purge button until all channels fire.
7. Wipe the orifice plate with a clean cloth and maintenance spray. Dry the orifice plate.
8. Observe the orifice plate for ink seepage over 30 seconds. Per the below diagrams, identify which orifice is leaking and its associated solenoid adjustment nut.
9. Turn the solenoid nut a very small amount counterclockwise (more pre-load) with a solenoid adjustment tool (see "Appendix H: Part Numbers").
10. Repeat steps 6. through 9. until the seepage stops.
11. If there are any nuisance valves that do not stop seeping, then the print head will have to be returned to the factory for refurbishment.

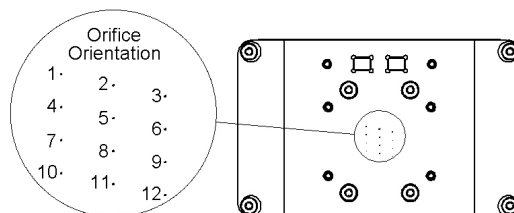
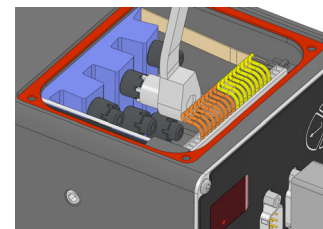
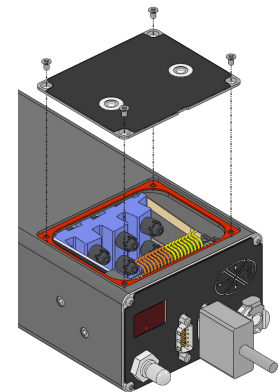

Appendix A: Specifications

System

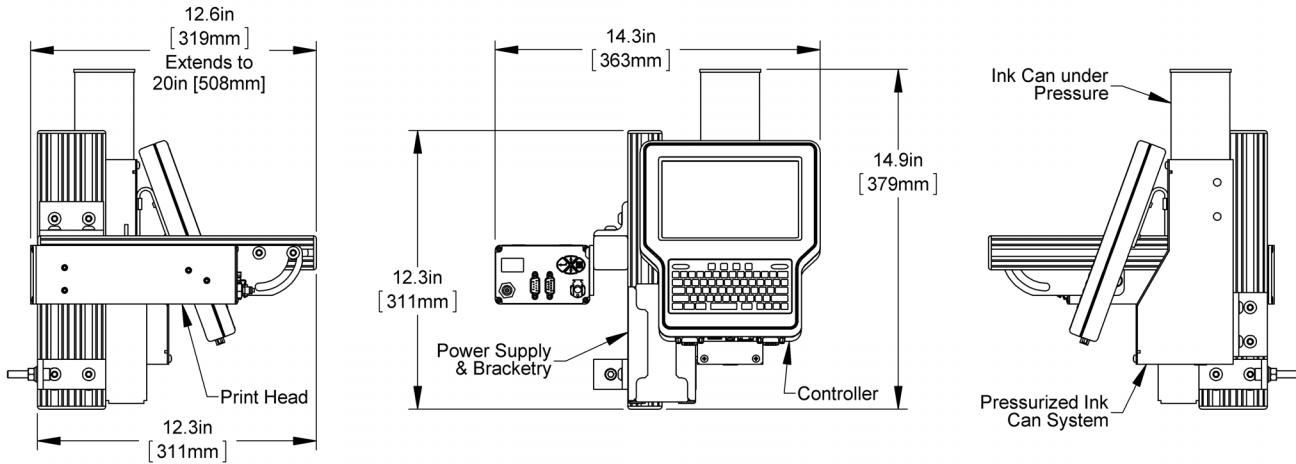

A typical system consists of the above components:

- Controller
- Print Head
- Pressurized Ink Can System
- Power Supply and Mounting Bracketry
- System Mounting Bracketry
- * Ink purchased separately



NOTE: The system mounting bracketry is shown in a typical configuration. Bracketry and print head orientation is left to the user to fit the application.

Typical Print Head and Bracketry

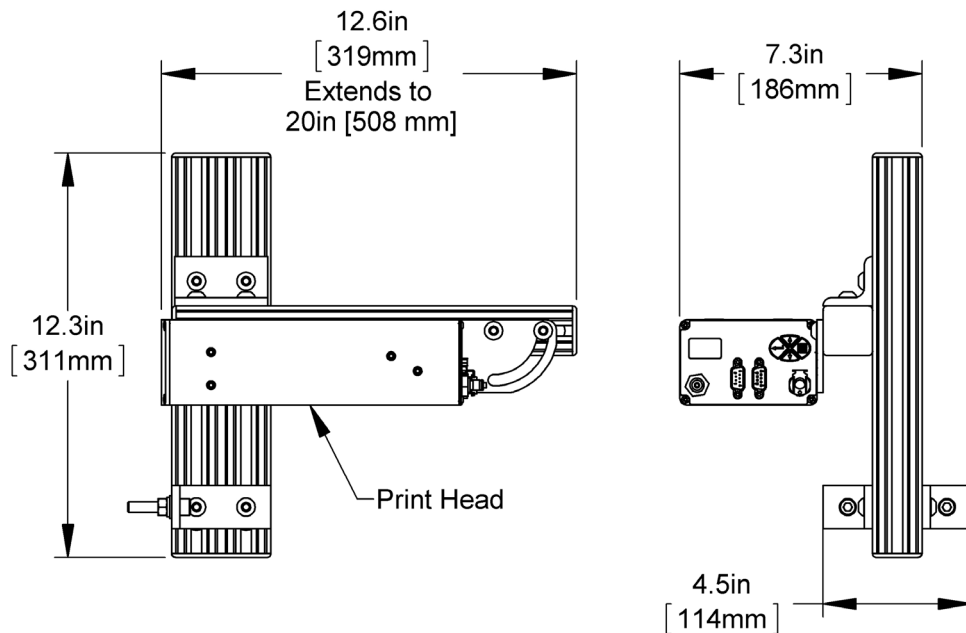

Print Head:

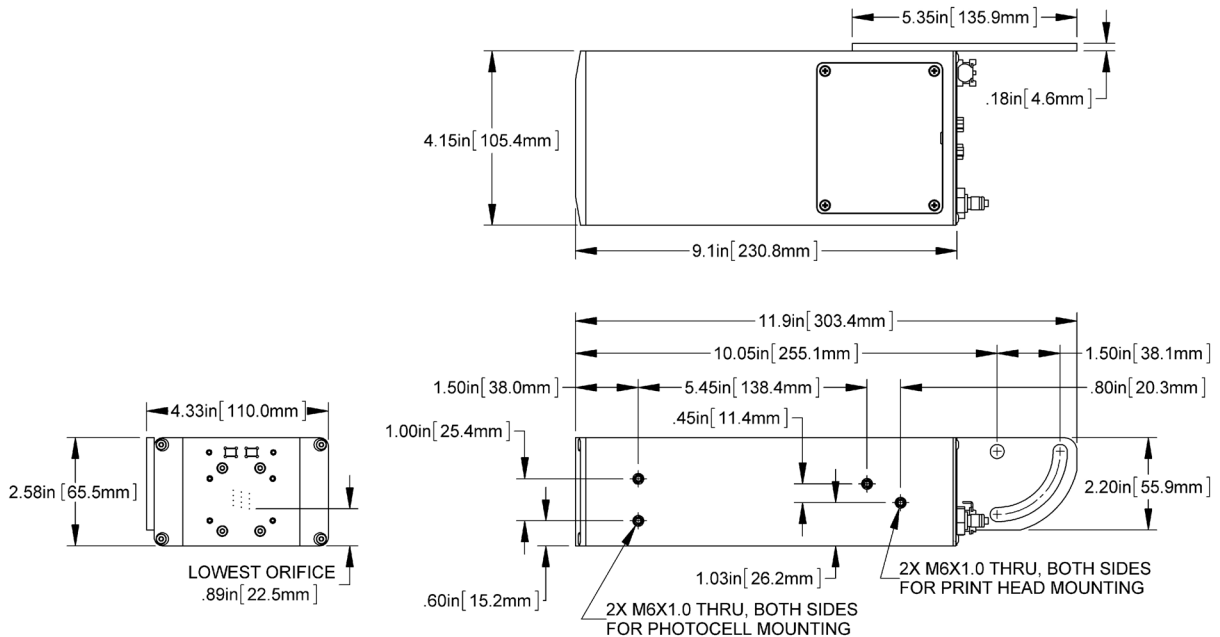

Weight

5.1 lb (2.3 kg)

Enclosure

Anodized Aluminum and Stainless Steel

Operating Pressure

7.0 psi (48.3 kPa)

Electrical

15 VDC input from controller

Print Speed (Print Resolution Dependent)

Up to 650 ft/min (200 m/min)

Vertical Print Resolution

24 dpi

Horizontal Print Resolution

Varies up to 33 dpi

Throw Distance

Recommended Gap: .1 in (2.5 mm) or less
Maximum Gap: .5 in (12 mm)

Print Head Orientation

Any

Environment

Ambient operating temperature: 50°F to 104°F (10°C to 40°C)
Operating humidity: 10% - 90% non-condensing

Ink Type

Porous (Water Based)

Non-Porous (Solvent Based)

Number of Print Fields

Maximum 2 lines of print per print head at any given point. Each print line may have at least three 52-character print fields; number of fields per line increases as the number of characters per field decreases.

File Storage

Sectors: Twenty-seven 256 kB sectors per print head are available for font and logo file storage. Files larger than 256 kB use multiple sectors. Factory installed fonts occupy 9 of the 27 sectors.

Fonts: Nine factory installed; 5s (5 dot tall single), 7sf (7dot tall single, fixed character spacing), 7b (7 dot tall bold), 9s (9 dot tall single), 9b (9 dot tall bold), 9bf (9 dot tall bold, fixed character spacing), 12s (12 dot tall single), 12b (12 dot tall bold), and 18b (18 dot tall bold).

Bitmap (logo) files: 12 dots tall max (.5 in / 12.7 mm); 5000 columns (dots) wide max (200 in / 5.1 m at 25 dpi).

Handheld Controller with Valve Jet Technology:

Weight

1.8 lb (0.82 kg)

User Interface

Type: Graphical User Interface

Keyboard: 70-key, QWERTY style, elastomeric keyboard

800 X 480 color LCD with touch screen, 7.0" (177.8 mm) diagonal

Fonts

5s (5 dot tall single), 7sf (7dot tall single, fixed character spacing), 7b (7 dot tall bold), 9s (9 dot tall single), 9b (9 dot tall bold), 9bf (9 dot tall bold, fixed character spacing), 12s (12 dot tall single), 12b (12 dot tall bold), and 18b (18 dot tall bold)

Storage

512 MB flash memory

Print Speed

Up to 650 ft/min (200 m/min)

Maximum Lines of Print

2 per print head

Print Fields per Line

At least (3) 52-character fields per print line; more when fields have less than 52 characters.

Maximum Product Length

200 in (5.1 m)

Maximum Repeat Print Distance

200 in (5.1 m)

Maximum Number of Print Heads Per Controller

4 (Up to 2 print heads per COM port)

Ports

(2) RS-232 ports, (1) 10/100Base-T Ethernet port, (1) USB port

Electrical

15 VDC from power supply to controller

Power Supply: 90-260 VAC, 50/60 Hz, 1.5A max. (per power supply)

Environment

Ambient operating temperature: 40°F to 104°F (5°C to 40°C)

Operating humidity: 10% - 90%, non-condensing

Maximum Distance Between Controller and Farthest Print Head in Daisy Chain

20 feet (6.1 m)

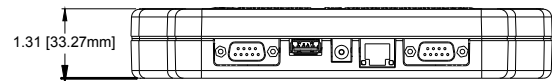
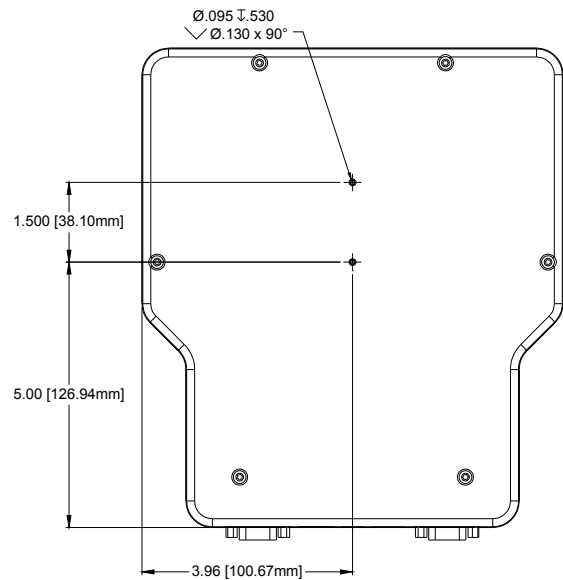
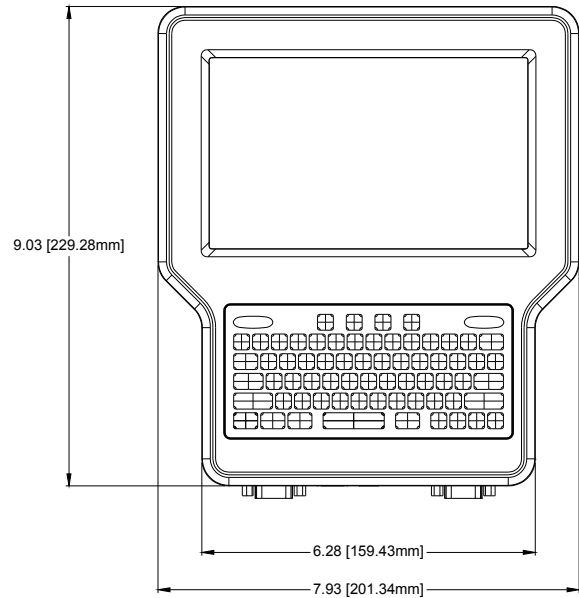

Pressurized Ink Can System

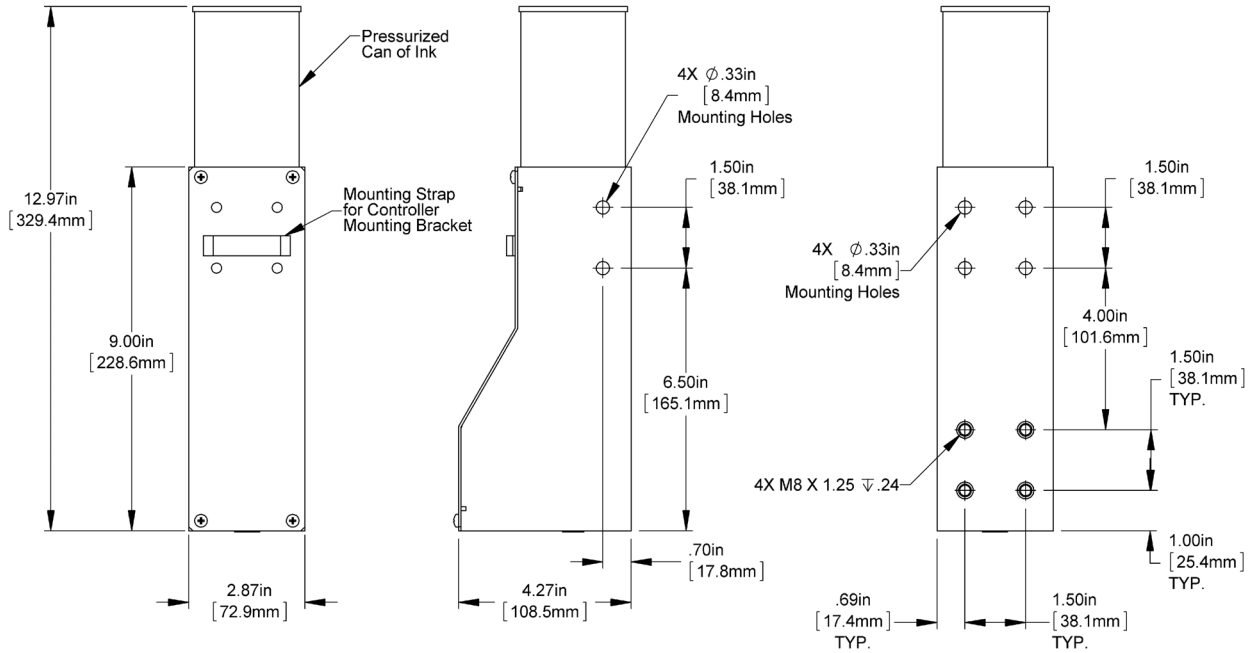

Weight

2.7 lb (1.2 kg)

Enclosure

Stainless Steel

Mounting Orientation

3 sides

Ink Capacity

13 fl oz (385 mL) screw top cans

Regulator

Factory set to 7.0 psi (48.3 kPa)

Maximum Number of Print Heads Capacity

4



NOTE: For more print heads, an optional pumping ink delivery system is available. See “Appendix H: Part Numbers” on page 47.

System Interconnect Diagram

Handheld Controller CPU Diagram

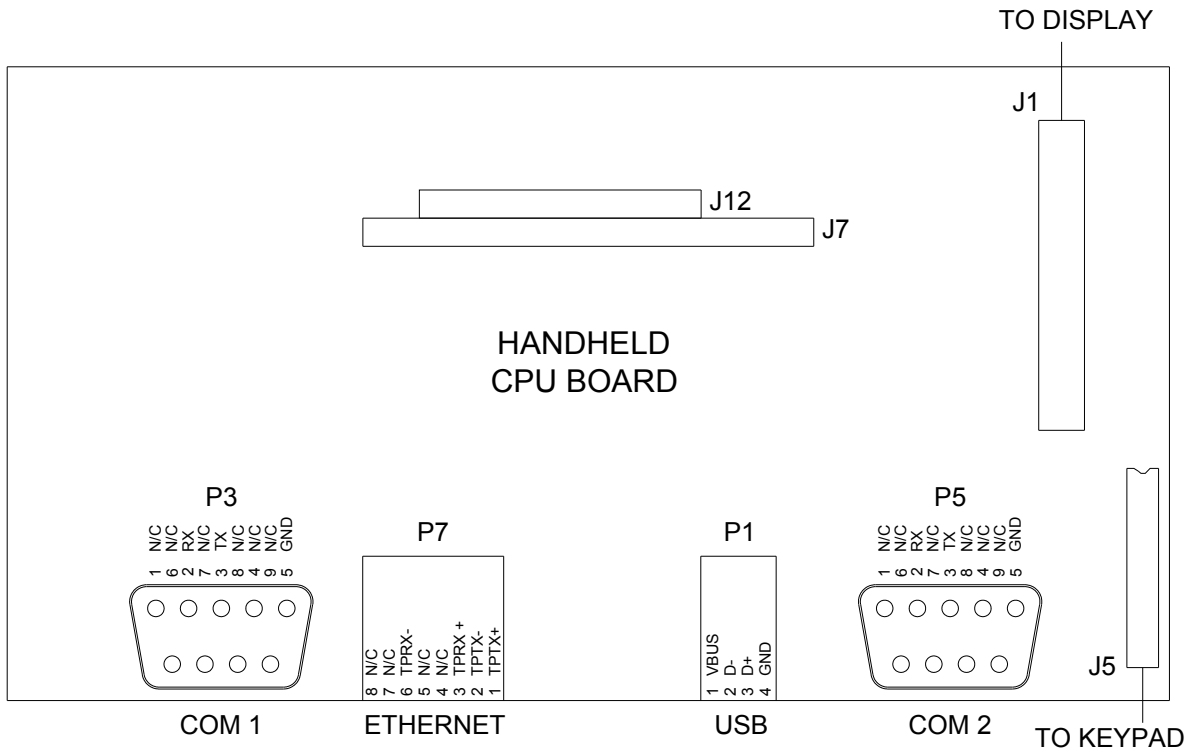

Print Head Diagram

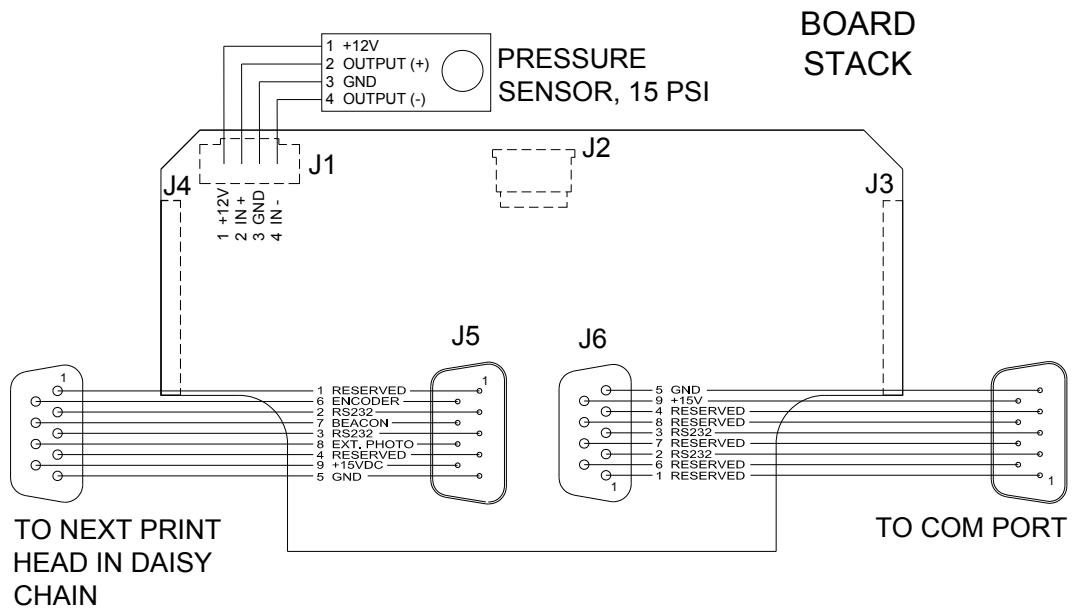

Appendix B: Serial Port Setup

Ensure the home screen menu is present via the **Hide Menu / Show Menu** button, and then press the **Control Panels** button.

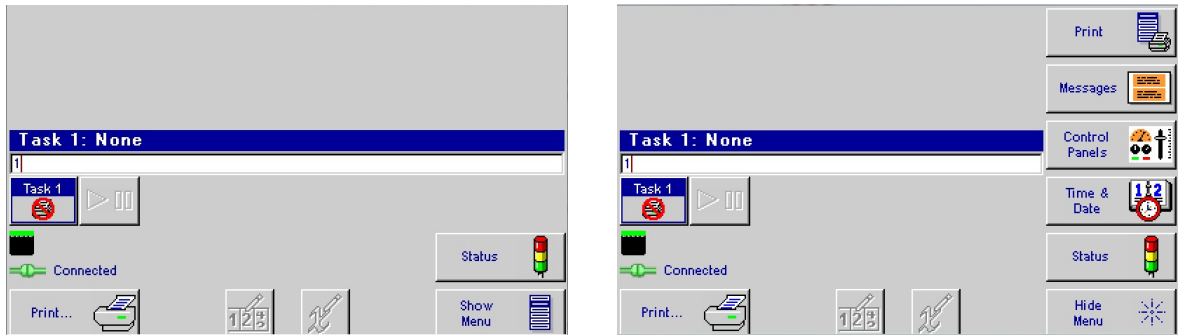

Press the **System Setup** button, and then the **Serial Ports** tab.

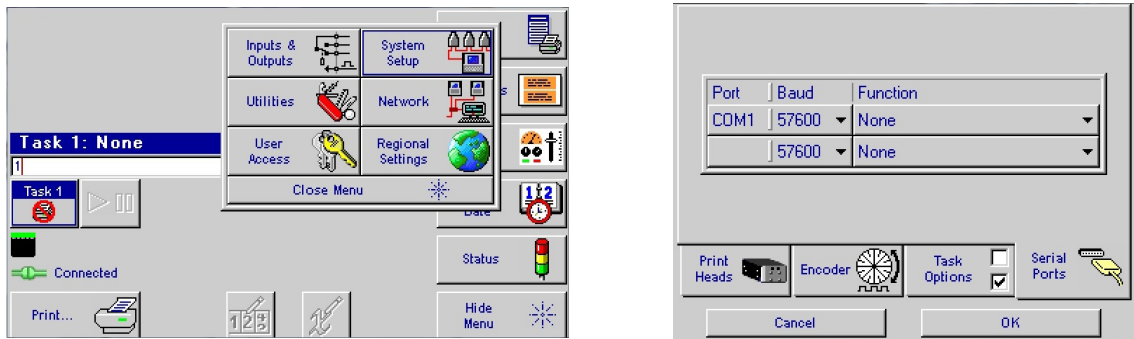

Select the device type under the **Function** heading. It may be set to "None". Scroll down the list and select "Serial Print Head - IV". Ensure the baud rate is set for **57600** and press the **OK** button to exit the **Serial Port Setup** screen.

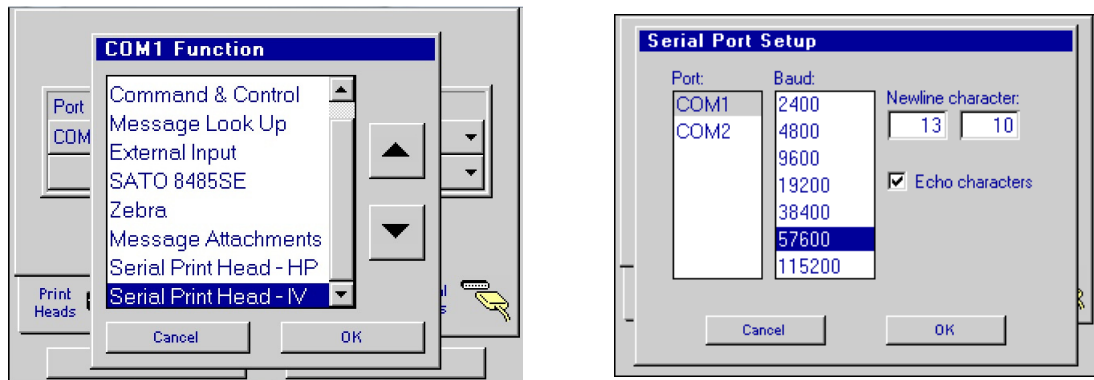

Appendix C: File System Backup and Restore

Backup

1. Insert a USB jump drive into one of the USB ports on the controller.
2. From the home screen touch **Control Panels** then **Utilities**.
3. From the **Utilities** screen select **Backup**.
4. Enter a file name at the **Backup** dialog popup. "backup" is the default name.
5. From the **System Utilities** screen select **Safely remove USB memory**.

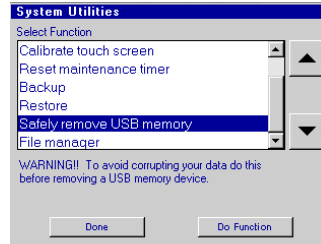
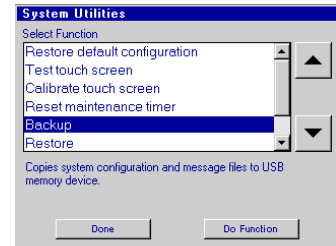
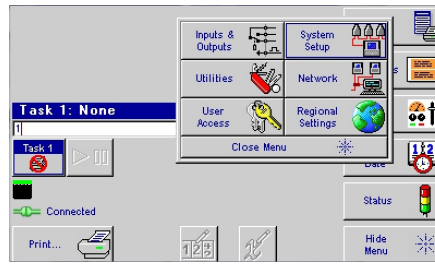

Restore

1. Insert a USB jump drive into one of the USB ports on the controller.
2. From the home screen touch **Control Panels** then **Utilities**.
3. From the **Utilities** screen select **Restore**.
4. Select the appropriate backup file from the **Restore** dialog popup.
5. From the **System Utilities** screen select **Safely remove USB memory**.

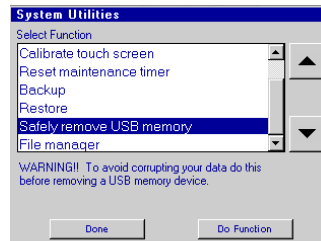
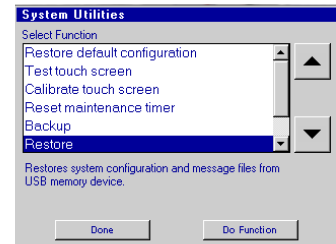
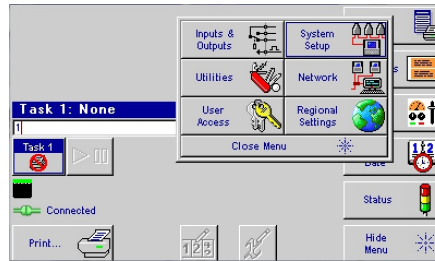

Appendix D: Configuring a PC to Communicate with the Handheld

Window 7®

1. Open the Start menu; select Control Panel; then Network and Sharing Center.

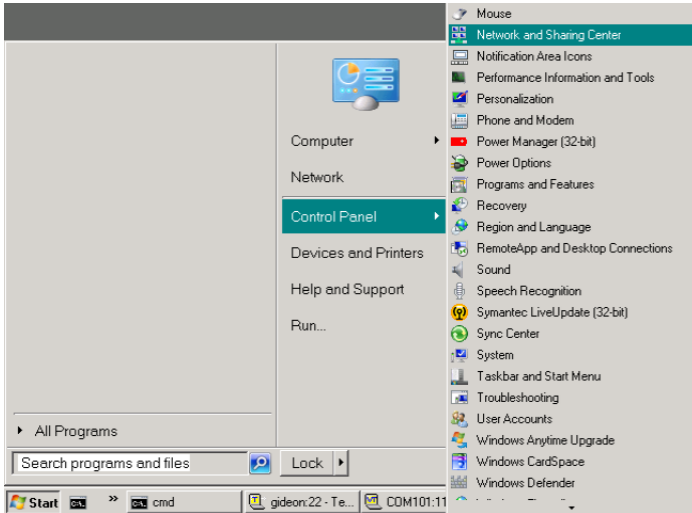

2. Click Local Area Connection, then click Properties button.

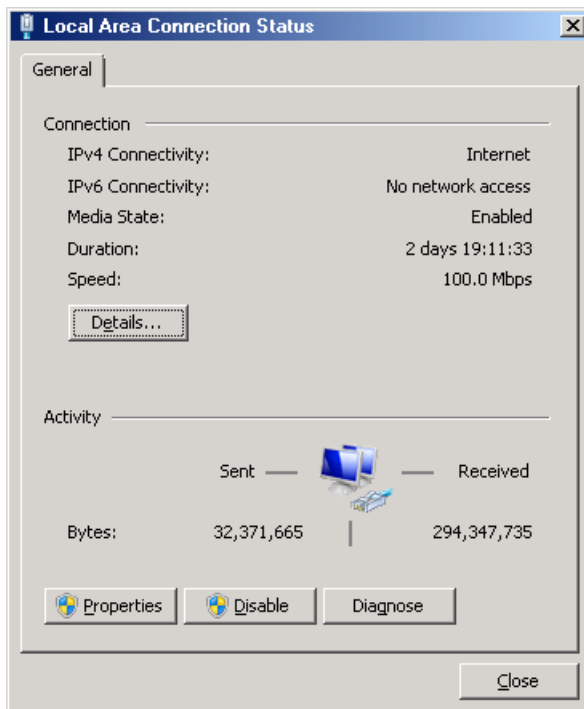
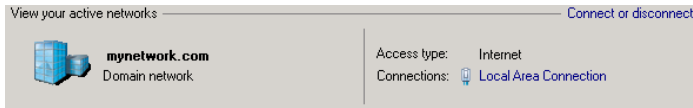

3. Select Internet Protocol Version 4 (TCP/IPv4). Then click the Properties button.

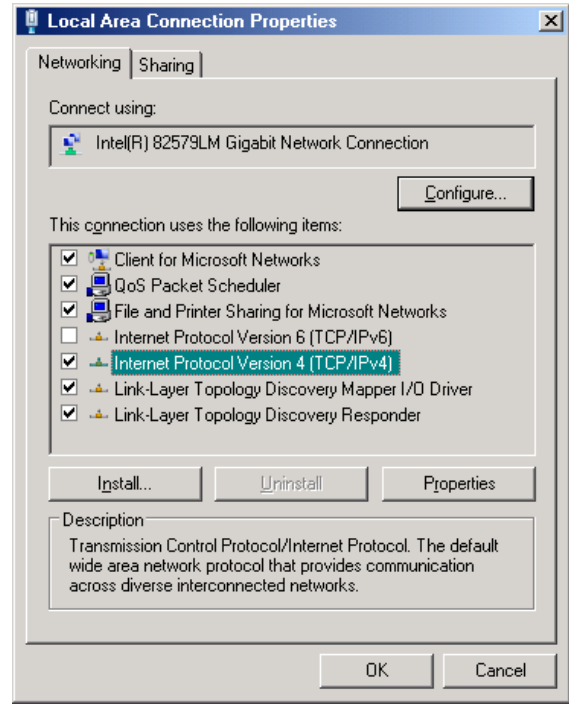

4. Click Use the following IP address radio button. Enter and IP address of 10.1.2.4, a subnet mask of 255.255.255.0, and click the OK button.

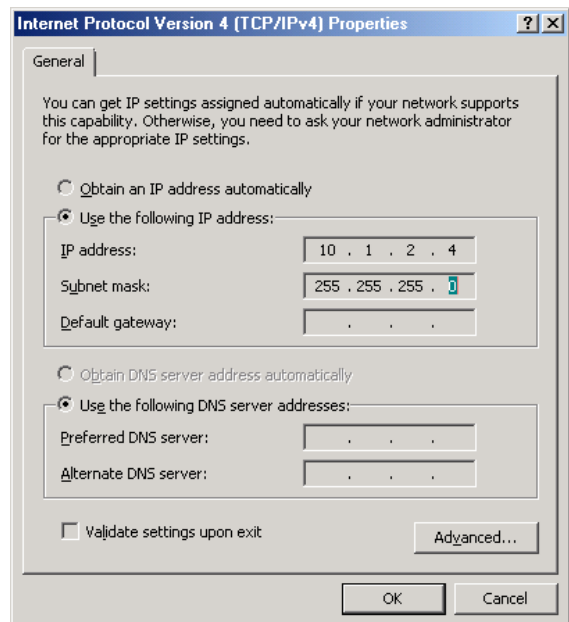

Appendix E: Creating Logo Files

Open **Paint** from a PC by selecting **Start, All Programs, Accessories**, and then **Paint**.

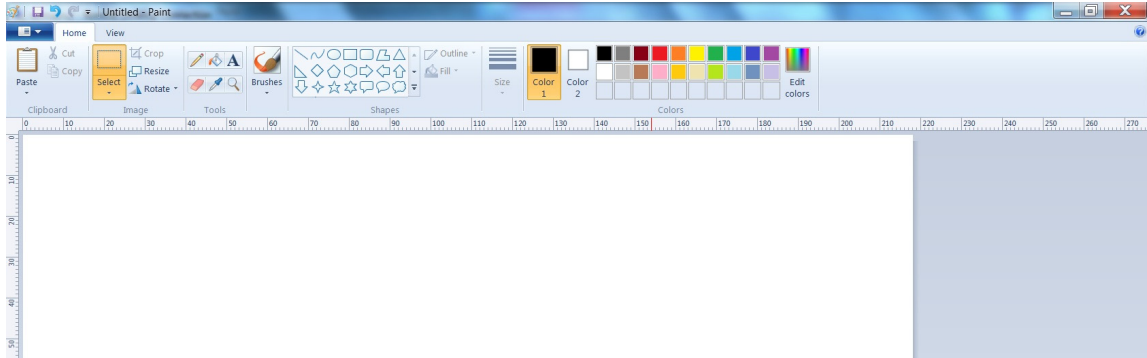

Navigate to the **Image Properties** dialog box via the drop down menu.

Enter the **Width** and **Height** of the logo in **Pixels**. For practical purposes the maximum height of a logo is 12 pixels if the logo is printed with a single print head. Maximum logo width is 5000 pixels, or print columns (200 in / 5.1 m when printed at 25 dpi.)

Select **Black and white** for the Colors.

Draw the pixels of the logo using the drawing tools. See the example below.

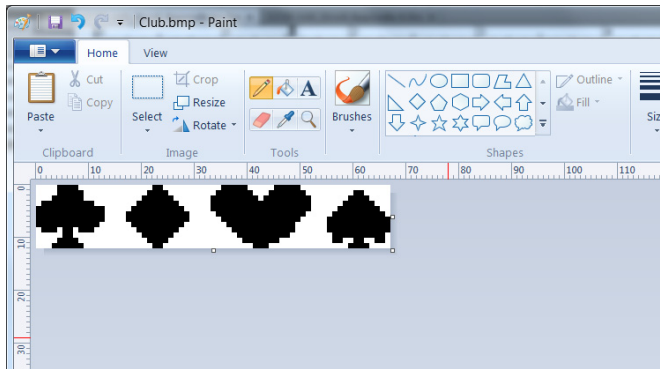
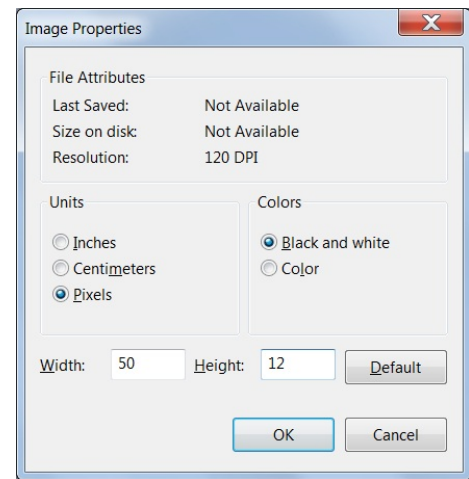

Next, click the **Rotate** button; **Rotate Left 90° (CCW 90°)**.

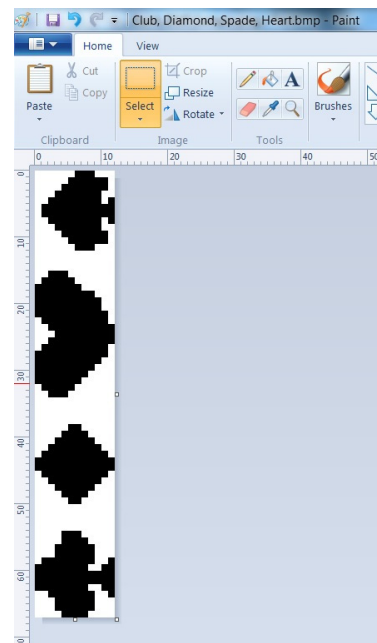

From the **File Menu**, select **Save As** and save the logo with a convenient name and directory location.



NOTE: If this logo is imported from another document or software, make sure that the first step taken is to **Save As a Monochrome Bitmap (bmp)**, and then **Resize** to the appropriate height (12 dot maximum for one print head).

Appendix F: Controller and Print Head File Management

File Manager



NOTE: A .bmp (logo) or .fnt (font) file must reside on both the controller and print head(s) to be correctly selected, displayed, and printed. Ensure the file names are less than 15 characters long.

1. If logo or font files are to be transferred, place them on a portable USB storage device in a convenient location and insert it into the controller USB port.
2. Touch the **Control Panels** button on the **Home** screen, and then select the **Utilities** button.

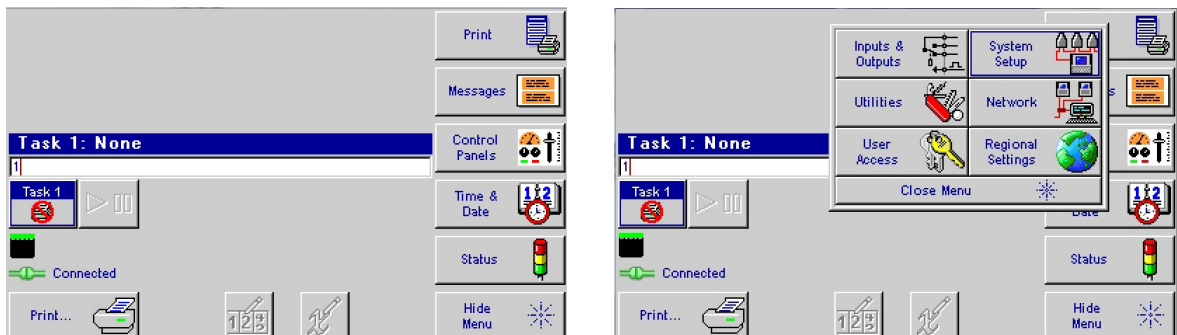

3. Scroll to the bottom of the **Select Function** list and select **File manager**. Press the **Do Function** button; the **File manager** screen is displayed.

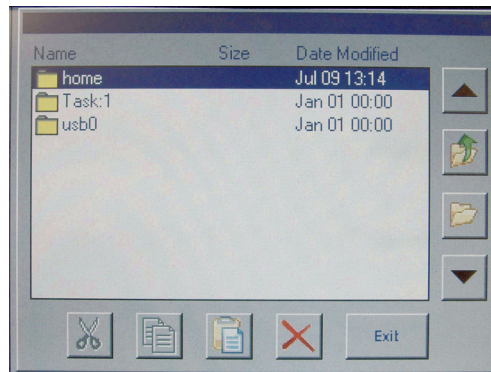
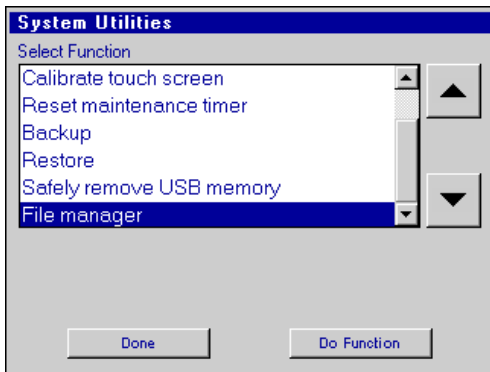

- Scroll Up
- Close Folder, Go Up One Level
- Open Folder
- Scroll Down

Cut Copy Paste Delete

The **home** folder contains all folders and files related to the controller operation.

The **Task:1** and / or **Task:2** folders contain all font and logo files resident on the print head(s) in that daisy chain.

The **usb0** folder contains all folders and files resident on the USB storage device.



NOTE: Cut, Copy, Paste, and Delete function the same way as any software. Navigate to any file in any of the folders and perform the desired function. In addition, however, files are not allowed to be copied from any task (the print heads).

Transferring Logo and Font Files



NOTE: Files cannot be transferred to the print head while printing. Pause print first.

1. As shown in the “File Manager” section, make sure USB storage device is installed and the **File manager** selection screen is present on the controller.
2. Select the **usb0** folder and press the **Open Folder** icon button.
3. Navigate to a previously saved file, highlight the file and press the **Copy** icon button. The file is now stored in temporary memory. In this example, a logo file will be transferred.
4. Press the **Close Folder, Go Up One Level** icon button until the **File manager** selection screen is present.
5. Select the **home** icon, press the **Open Folder** button, and highlight the **bmeps** folder. Store logos in the **bmeps** folder.

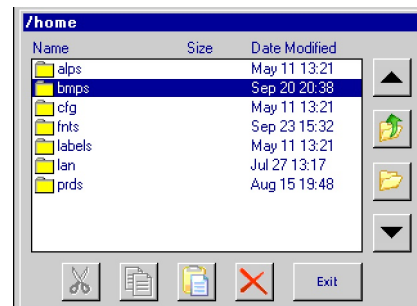
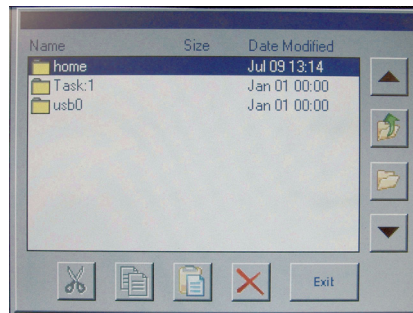

6. Press the **Paste** icon button. The logo (bmp file will appear in the **bmeps** folder.
7. Because the file is still resident in memory, it can be easily transferred to the print head(s). Navigate back to the file manager home screen. Highlight the **Task:1** or **Task:2** icon and press the **Open Folder** icon button.
8. Finally, press the **Paste** icon button, and the file appears on **Task:1** or **Task:2**. If the file is desired on the opposite task (daisy chain), navigate back and repeat the process. Note that the available fonts are listed in the Task folder too.

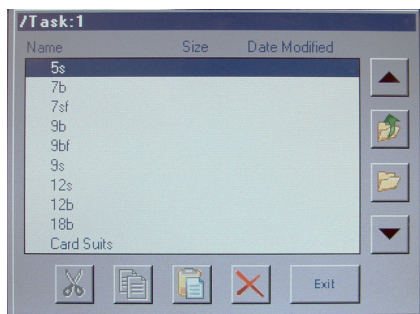
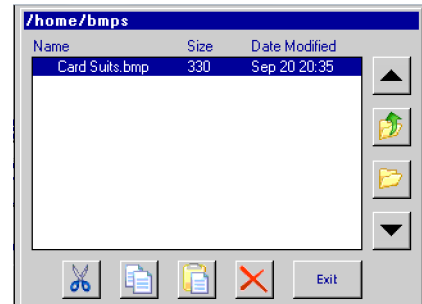

9. When all desired file transfers are complete, press the **Exit** button.
10. From the **System Utilities** menu, press the **Safely remove USB memory** button, and the **Done**.

The logo shown in the message editor.

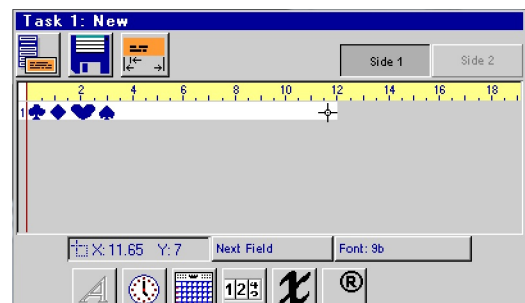

11. The file is now available for message creation in the message editor.

Appendix G: Communicating Directly to the Print Head

The print heads can be controlled by direct serial communication. Refer to the serial protocol document 5780-316N when communicating directly to the print head without the use of a controller or the pc GUI software interface.

Appendix H: Part Numbers

System

Major Components

Item	Kit No.	Description
1	5770-010PFX	Pressurized Ink Can System for Porous Inks
2	5770-010NPFEX	Pressurized Ink Can System for Non-Porous Inks
3	5770-012P500FX	Valve Jet Print Head with Bracketry, Plumbing, and Serial Cable for Porous Inks
4	5770-012N500FX	Valve Jet Print Head with Bracketry, Plumbing, and Serial Cable for Non-Porous Inks
5	5780-015FXV	Handheld Controller
6	5780-236D	Power Supply and Bracketry

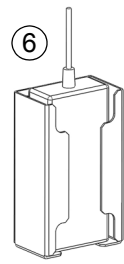
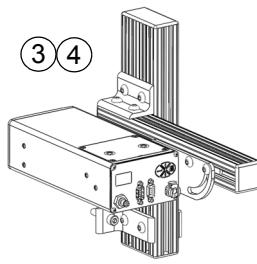
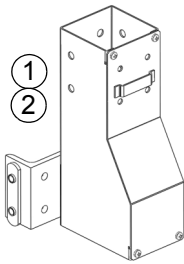

Consumables

Inks, Conditioners, and Maintenance Sprays

Part No.	Description	Package	Shelf Life
5750-242	Conditioner Flush, Porous, Cans	2 / case	1 year
5750-243	Ink, Porous, Black, Cans	6 / case	
5750-249	Maintenance Spray, Porous, Cans	2 / case	
5750-650	Conditioner Flush, Non-Porous, Cans	2 / case	
5750-651	Ink, Non-Porous, Black, Cans	6 / case	
5750-657	Maintenance Spray, Non-Porous, Cans	2 / case	

* Optional inks available with optional bulk ink supply.

Service Parts

12 Dot Valve Jet Print Head

Item	Kit No.	Description
1	5770-239P500FX	Print Head Replacement, Porous Ink
2	5770-239N500FX	Print Head Replacement, Non-Porous Ink
3	5770-242P	PCB Replacement for Porous Print Heads (all boards included)
4	5770-242N	PCB Replacement for Non-Porous Print Heads (all boards included)
5	5770-243	Internal Tubing and Fitting Replacement (not shown)
6	5780-451-010	Cable, Print Head, 10'

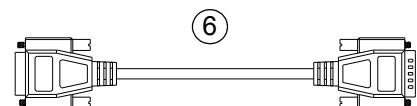
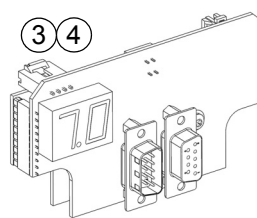
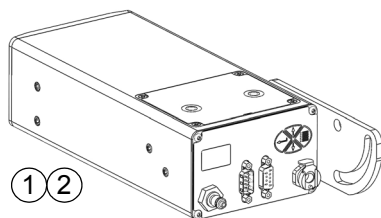

Handheld Controller

Item	Kit No.	Description
1	5780-015FXV	Handheld Controller
2	5780-232	Color Display Replacement
3	5780-233	CPU PCB Replacement

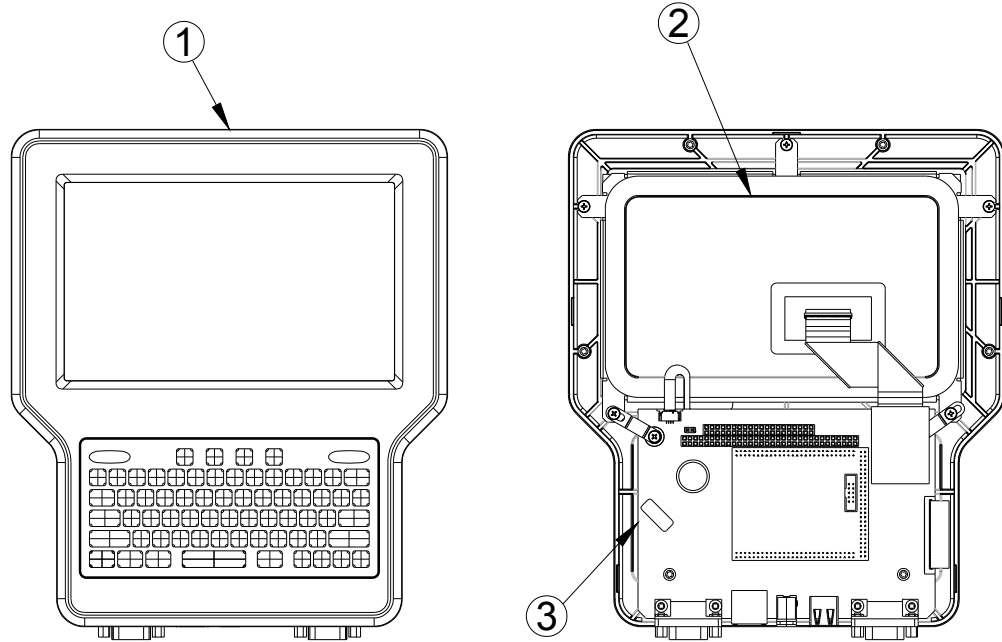

Bracketry

Item	Kit No.	Description
1	2464-561	X-Y Linear Print Head Adjustment, Tool-less
2	5760-821	Print Head, Pressurized Ink Can, and Power Supply Mounting

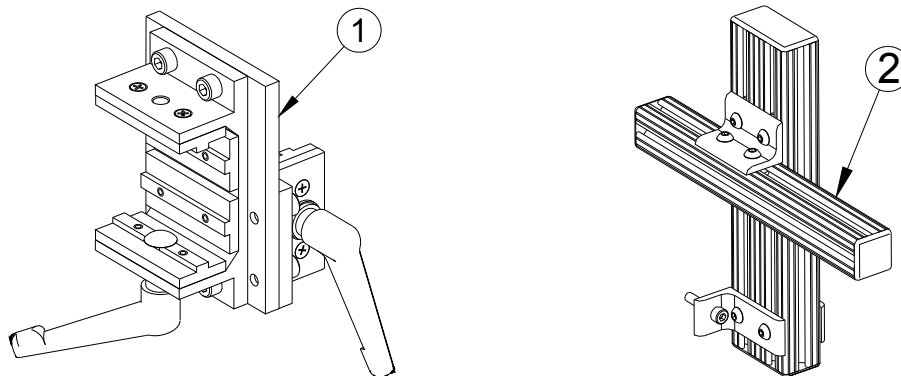

Optional Equipment

Encoder, Photocell, Accessory Hub, and Beacon

Item	Kit No.	Description
1	5760-820-IJ	Encoder Assembly with Mounting Bracket & 25' Cable
2	5765-206	Encoder O-ring Replacement
3	5760-383	Photocell
4	5780-339	Adaptor Cable, Encoder & Photocell

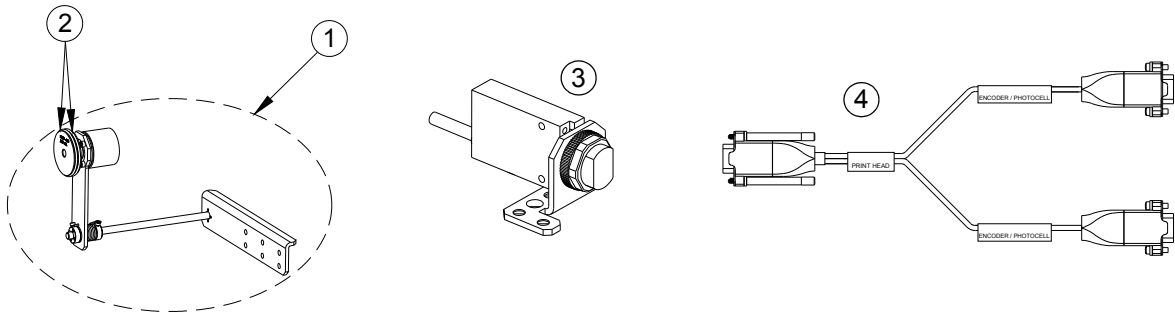

Tools and Maintenance

Item	Kit No.	Description
1	1901-398	Hand Cleaner, Ink (not shown)
2	5770-244	Broach, Orifice
3	5750-503	Effluent Bottle Kit
4	5770-201	Solenoid Pre-load Adjustment

